



 Puretec®

HYBRID **H7**



HYBRID **H7**

Filtration & Ultraviolet All in One Unit

 **Puretec®**
PERFECTING WATER



- **Stainless Steel Hinged Lid**
Easy accessibility for lamp change
- **Weather Protection**
The Hybrid incorporates a weather cover for outdoor installations
- **Easy Installation**
4 mounting points for quick and easy installation
- **Anti-Corrosion Construction**
Stainless steel bracket, lid and chamber ensures no rusting
- **Neatly Concealed Control Panel**
Monitors the lamp life, failure alarm (audible & visible) and total running days of the Radfire UV unit
- **Anti-Tamper Design**
Anti-tamper and childproof lockable lid

1 Sediment Filtration

A washable sediment filter that removes silt, sludge, dirt and rust

2 Taste and Odour Removal

The carbon cartridge reduces taste, odour and chemicals

3 Ultraviolet Protection

Kills 99.9% of bacteria with Radfire ultraviolet technology, a natural purification process that's completely eco-friendly and chemical-free

Puretec Hybrid H7

Enjoy the peace of mind of safe, purified water at every outlet in the house. The Puretec Hybrid H7 system is highly effective and efficient in reducing taste, odour, chemicals and sediment in your water, giving good general purpose filtration. This system eliminates 99.9% bacteria in your water.



Puretec Hybrid H7

Provides safe and purified water at every tap

THE HYBRID H7 KILLS 99.9% OF BACTERIA

Thanks to its advanced UV technology – called Radfire™ – the Hybrid H7 kills 99.9% of tank water bacteria. Nothing else even comes close. Radfire™ is a natural water purification process, that's ecofriendly and completely chemical free. So you get safe, purified water at every outlet in the house.

IT FILTERS YOUR WATER TOO

As its name suggests, the Hybrid combines two technologies to clean your water. In addition to killing 99.9% of bacteria with UV rays, it filters out chemicals, as well as sediment and anything else that manages to pass through your rainwater tank's coarser filter. This not only makes your water taste and smell great, but also prolongs the life of your household appliances.

LONGER FILTER LIFE

Hybrid H7 incorporates Puretec's long life filter technology, so you can go longer between filter replacements, and comes with our 3 Year Platinum Protection Warranty[^].



- ✓ Quick and easy installation
- ✓ Turns your tank and mains water into pure, safe, delicious drinking water
- ✓ Kills 99.9% of bacteria with Radfire™ ultraviolet technology, a natural purification process that's completely eco-friendly and chemical-free
- ✓ Designed for Australian harsh climate
- ✓ Heavy duty stainless steel cover for maximum durability
- ✓ Double O-ring filter housings for leak-free protection
- ✓ Equipped with a lamp count-down timer and alarm (audible & visible)
- ✓ Anti-tamper & child-proof lockable lid
- ✓ Hinged lid for easy access for lamp change
- ✓ 3 year warranty[^]

SPECIFICATIONS

Product Code:	HYBRID-H7
Replacement Parts:	
Sediment Cartridge	PL05MP2
Taste & Odour Removal	DP10MP2
Lamp	RL5
Flow Rate:	75-110 Lpm
Maximum Temp:	52°C
Maximum Pressure:	875 kPa
Connection:	1" BSP [25mm]
Warranty:	3 years[^]

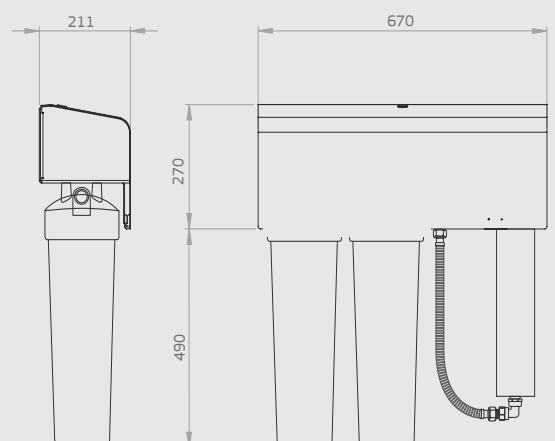

HYBRID

MAINS AND RAINWATER FILTRATION

Distributor's Details

Puretec water care products are designed, manufactured and supported by Puretec Pty Ltd the name you can trust for viable and proven water solutions. The complete range of Puretec products are developed, refined, made to meet and exceed stringent specifications for the worldwide market. All pictures and information are supplied as a guide only. *Fittings not Included. ^3 Year Platinum Protection applies to Puretec Systems when used in conjunction with a Puretec filter cartridge. Warranty excludes cartridges.

Important Note: Sales of products are subject to our Terms and Conditions which are available upon request. All specifications, information and photos are a guide only and are subject to change without notice. Please ring to confirm details. Warning: For correct operation of this appliance it is essential to observe manufacturer's instructions. Caution: Do not use with microbiologically unsafe water or water of unknown quality without adequate disinfection before or after the system. Under normal circumstances a pressure limiting valve is not required. However, if incoming water pressure exceeds 875 kPa, a pressure limiting valve must be fitted prior to inlet. Copyright © Puretec Pty Ltd 2015



AUSTRALIA
P 1300 140 140
E sales@puretec.com.au
W puretec.com.au

NEW ZEALAND
P 0800 130 140
E sales@puretec.co.nz
W puretec.co.nz