

KELCO F60 DIGITAL PUMP CONTROLLER

INSTALLATION INSTRUCTIONS

Table Of Contents

Warning Symbols Explained.....	1
Important Safety Instructions.....	2
Overview.....	3
Installing the F60.....	4
Before or After the Air Cell.....	5
Warning Message.....	6
Installation.....	7
Aligning Paddle Assembly.....	8
Locking the Electrical Assembly Onto The Paddle Assembly.....	9
Trimming the Paddle.....	10
Detaching the Electrical Housing.....	11
Sensitivity Adjustment.....	12
Limitations.....	13
Table of Limitations.....	14
Electrical.....	15
Brownout or Blackout.....	16
Cable Gland Assembly.....	17
Electrical Limits.....	18
Remote Input	19
Wiring Diagrams	21
The 12VDC F60 Pump Controller.....	27
F60 Layout.....	28
Table of Controls and their Functions.....	29
Maintenance, Spare Parts, Warranty.....	30



WARNING

This symbol is intended to alert the user to the presence of important operating and maintenance instructions in the literature accompanying the pump controller



WARNING

This symbol is intended to alert the user to the presence of un-insulated “dangerous voltage” within the pump controller’s enclosure that may be of sufficient magnitude to constitute a risk of severe electric shock.

IMPORTANT SAFETY INSTRUCTIONS

- Read these instructions.
- Do not modify this controller in any way.
- Keep these instructions.
- Heed all warnings.
- Follow all instructions.
- Do not allow water to enter this controller.
- Install this controller per the manufacturer's instructions.
- Do not install this controller near any heat source such as radiators, gas heaters, stoves, or any other appliance that produces heat.
- Do not drill holes in this controller's casing.
- Refer all installation and servicing to qualified service personnel.
- Servicing is required when the controller has been damaged in any way, such as exposed to fire, dropped, had objects dropped on it or been exposed to moisture or water when the controller's lid is removed.



WARNING

Please read these installation and operating instructions fully and carefully before installing or servicing this controller. The F60 Pump Controller is a mains voltage device. Death or serious injury may result if this product is not correctly installed and operated.

Overview

The F60 digital pump controller is a powerful flexible controller that can be configured in a variety of ways to control a pump and to protect it against running dry. The controller can be set to operate in one of three fundamental modes. Within each mode a number of functions can be selected using the controller's simple programmable interface. This document sets out in detail the installation and functions of the controller and some of the main ways in which it can be used in pumping and irrigation systems.



WARNING

Without its lid in place the F60 is not water resistant and presents a potential shock hazard. Take great care not to splash water onto the F60 when the lid is not in place. Always replace the lid and fully tighten its 6 securing screws immediately after any changes to the controller's settings are made.

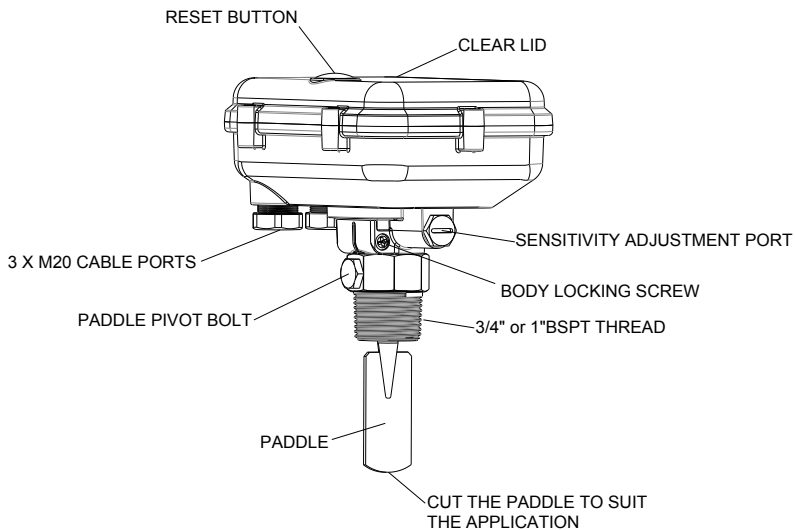

INSTALLING THE PUMP CONTROLLER

Location

Install this controller in a location that is sheltered from direct exposure to the weather. The F60 is weatherproof; however, to ensure a long reliable life from the controller we recommend it be protected from direct exposure to the sun and rain. Intense sun light will eventually cause discoloration of the clear lid on the controller and will also degrade its LCD screen. It is therefore advisable to always protect the controller from the weather with some form of shielding.

The F60 should be installed in a straight section of pipe preferably with 5 diameters of straight pipe either side of the paddle. The controller can be installed in a suitable pipe socket, tapping saddle or pipe tee. The controller should be installed in the discharge pipework of the pumping system, either before or after the system's air cell. If the system does include an air cell a decision has to be made as to which side of the air cell to locate the controller. The fundamental way the system operates will depend on this decision. The F60 should not be installed in the suction pipe of a pump as it requires positive pressure to operate properly. The F60 can be installed in either horizontal or vertical pipe. If it is installed in vertical pipe the flow must be in an upward direction. Do not install this controller on the underside of horizontal pipework.



VERY IMPORTANT

DO NOT INSTALL THE F60 IN ANY LOCATION THAT EXPOSES IT TO DIRECT SUNLIGHT. IN A FULLY EXPOSED INSTALLATION ALWAYS PLACE SOME FORM OF SHIELDING OVER THE CONTROLLER TO PROTECT IT FROM DIRECT EXPOSURE TO THE SUN. FAILURE TO PROTECT THE CONTROLLER FROM DIRECT EXPOSURE TO THE SUN MAY CAUSE IT TO OVERHEAT AND MAY REDUCE ITS OPERATING LIFE.

Before The Air Cell

If the F60 is installed before the air cell in the system it will only start the pump on pressure since the initial draw off will be supplied from the air cell. The only change in state the controller will see will be the falling pressure. Choose this arrangement if you want to keep pump starts to a minimum and you are prepared to accept the delay in starting associated with the slow pressure fall from the air cell.

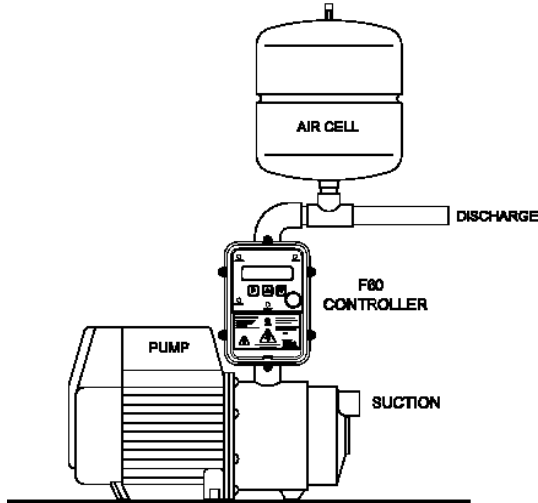

CONTROLLER INSTALLED BEFORE THE AIR CELL

After The Air Cell

If you install the F60 in the pipework after the air cell the controller will start the pump each time flow pushes its paddle forward or each time pressure falls to whatever pressure you have set the controller to start at. Choose this arrangement if you want the system to deliver a fairly steady pressure and to start each time flow is sensed.

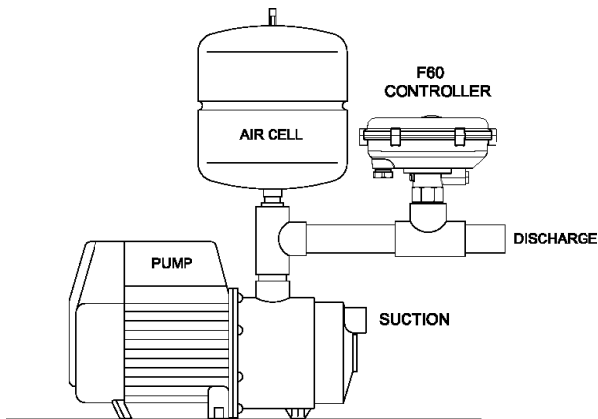

F60 PUMP CONTROLLER INSTALLED AFTER THE AIR CELL



WARNING

After programming the F60 always replace its lid and fully tighten all 6 securing screws. Also ensure all cable glands are fully tightened. Never leave the lid off the controller for extended periods. Without its lid in place the F60 is not water resistant and presents a potential shock hazard. Take great care not to splash water onto the controller when the lid is not in place. Without its lid the controller is not weather or insect proof and presents a potential shock hazard that may result in death or serious injury.

Installation

The F60 pump controller is supplied as two separate assemblies, the paddle assembly and the electrical housing. The paddle assembly should be installed in the pipework first and the electrical housing should then be fitted onto the spigot on top of the paddle assembly, taking care that the sealing O-ring is on the stem and is in location and in good order. There is a flat keying face on the cylindrical body of the paddle assembly that keys the electrical housing onto the paddle assembly and aligns it correctly. It is critical that the keying flat is on the downstream side and at 90 degrees to the axis of the pipework (see sketch). To secure the electrical housing onto the paddle assembly an Allen head cap screw is supplied.

With the electrical housing located on the spigot and in position, press down with the flat of your hand on the top face of the lid of the electrical enclosure. While pressing down, screw the 4mm Allen screw fully through the housing using the 3mm Allen Key (supplied). Tighten the screw and then release your hand from the top of the housing. Pressing down with your hand on the housing preloads the O-ring seal between the housing and the paddle assembly. It enables the M4 Allen screw to easily screw fully through the side of the housing.

Under no circumstances should the electrical housing be twisted or used to screw the paddle assembly into the pipework, or to align the controller with the axis of the pipework. To do so will irreparably damage the controller and void its warranty. Never apply water pressure to the controller unless the M4 locking screw is in place and fully tightened (see sketch for details). To fit the paddle assembly into the pipework use a suitable spanner and use the spanner flats provided on the paddle assembly (directly above the process connection thread).

The F60 can be installed in either vertical or horizontal pipe. When installed in vertical pipework flow must be in an upward direction past the controller's paddle. The F60 may have been supplied with either a ¾" or 1" BSP or NPT process connection. A matching female threaded socket or pipe tee must be provided to fit the controller into pipework.

ALIGNING THE PADDLE ASSEMBLY

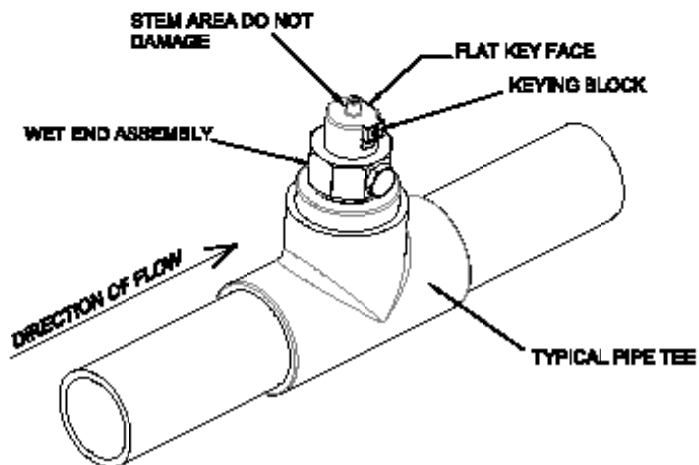
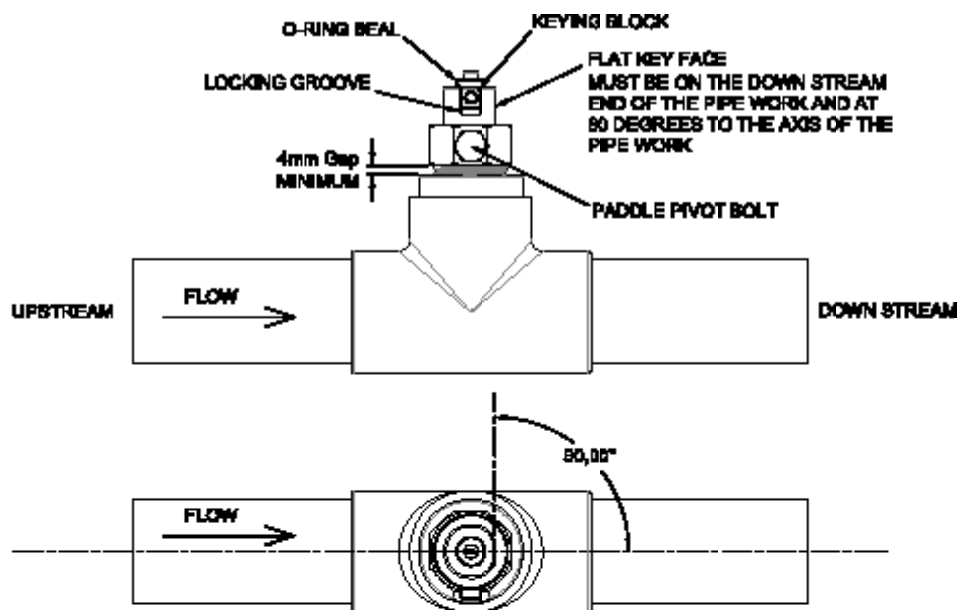

Locking the electrical housing onto the paddle assembly

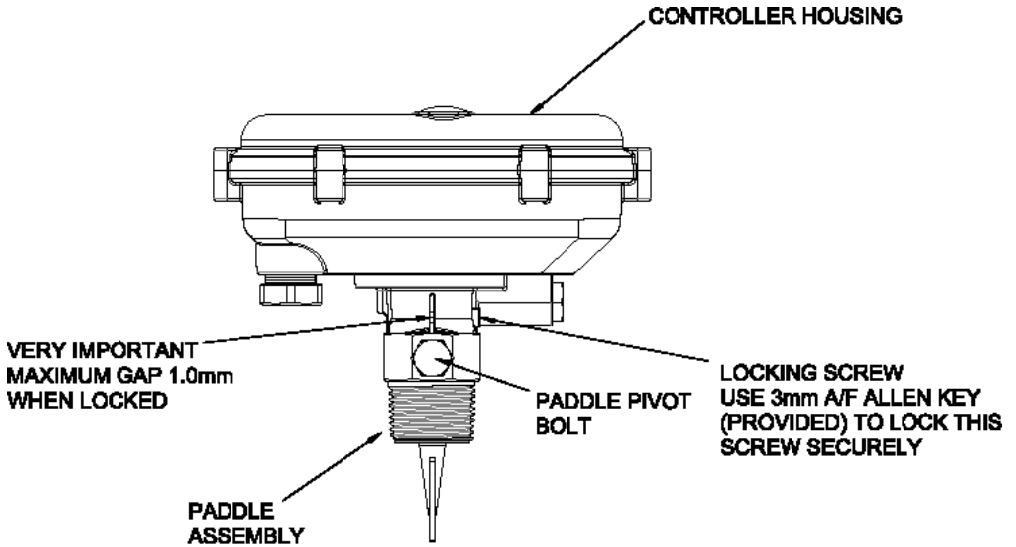

Trimming the paddle

The paddle of the F60 can be cut down to suit the specific pipe size and intended application. Cut the paddle using a hacksaw or tin snips so it clears the sides of the pipe socket and protrudes approximately half to two thirds of the way across the pipe when the controller is screwed into the pipework. If a low flow rate is expected through the system the paddle should be cut longer, perhaps until it only clears the bottom of the pipe by 5mm. If you are unsure as to what length the paddle should be, a paddle trimming calculator is available at www.kelco.com.au If you know what the expected flow rate is the calculator allows you to enter your pipe diameter and paddle dimensions. It will then determine if the selected paddle dimensions are adequate for the application. Spare paddles to suit the F60 pump controller are available from Kelco or from your distributor.

Apply sealing compound or Teflon tape to the process connection thread on the controller and screw the controller into the pipework using the spanner flats on the process connection. Do not screw the controller into the pipework by twisting the electrical housing. The controller can be permanently damaged by twisting the electrical housing. When correctly installed there should be a minimum 4mm gap between the top of the pipe socket and the top of the thread on the F60. The controller must be square to the axis of the pipework with the direction of flow arrow pointing in the direction of flow.

Detaching The Electrical Housing

To allow easy access to the controller's paddle, the electrical housing of the F60 can be detached from the paddle assembly. Removing the electrical housing allows access to the paddle without the need to disconnect the electrical connections to the controller. To remove the electrical assembly, switch off the system's power and undo and completely remove the M4 Allen head locking screw (see diagram). Once the locking screw is removed, lift the electrical housing straight off (do not twist it when doing this). Once the electrical housing has been removed, the paddle assembly can be unscrewed from the pipework using the spanner flats on the body of the paddle housing. Simply reverse this procedure to refit the electrical housing to the controller, taking care to ensure the pressure seal O-ring on the top of the wet end is in place and is clean and in good condition.



WARNING

Always de-pressurise the piping system before removing the electrical housing or carrying out any work on the paddle assembly of the F60. The securing screw that locks the electrical housing onto the paddle assembly of the F60 must never be loosened or removed while the pipe system is under pressure. In order to carry out any work on the paddle itself, the pipe system must be completely depressurized and vented to atmosphere. If the F60 is located in a section of pipework that is flooded then that section of pipework must be fitted with isolation valves and the valves must be fully closed before removing the paddle assembly from the pipework.

Sensitivity Adjustment

Under the end of the electrical housing on the F60 is a red hexagonal dust cap. If you remove this dust cap you gain access to an adjustment screw that allows the paddle preload to be reduced. As supplied the sensitivity adjustment screw is wound fully in.

In this position the paddle is at its least sensitive. In this position it takes a substantial force from the moving water to move the paddle. If you wind the sensitivity adjustment screw anti-clockwise (outward) the force against the paddle that resists flow will be reduced.

The paddle will become increasingly more sensitive and will respond to progressively lower and lower flows the further out you wind the adjusting screw. The total adjustment range is 10 turns of the screw. If you wind the adjustment screw out beyond 10 turns there will not be enough residual force to return the paddle to the off position when flow stops.

The range of sensitivity adjustment will also be affected by the orientation of the controller. In horizontal pipework with the F60 mounted vertically the useable range of adjustment is approximately 8 turns. In vertical pipe with the F60 installed horizontally the full 10 turn range can be utilised.

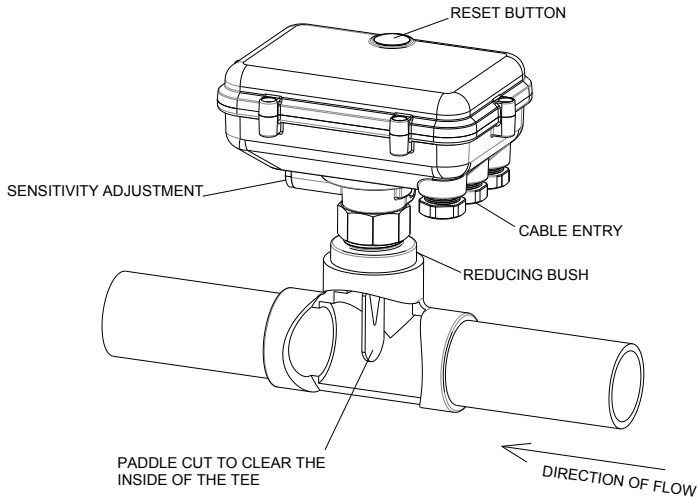

TYPICAL PIPE TEE INSTALLATION

Limitations



WARNING

The F60 pump controller is water resistant to IP67. This rating only applies if the clear lid and its gasket are in place and the lids 6 fixing screws are fully tightened. The F60 is not water resistant unless the clear lid is in place and fully secured and all cable glands are correctly assembled and tightened. Always replace the clear lid and fully tighten the 6 securing screws after making changes to the controller's settings. The F60 may present a shock hazard and death or serious injury may result if water enters the controller's electrical housing. There are no user serviceable parts in this pump controller. Under no circumstances should the main electronics housing be opened. Warranty on this product is automatically void if the electronics compartment is opened.

1) Do not install this controller in a fully exposed outdoor location. The F60 is weatherproof, however, to ensure a long reliable life from the controller we recommend it be protected from direct exposure to the sun and rain. Intense sun light will eventually cause discoloration of the clear lid on the controller and will also degrade the unit's LCD screen. It is therefore advisable to always protect the controller from the weather with some form of shielding.

2) Do not expose this controller to freezing. If the pipework in which the F60 is installed freezes, the pressure sensor in the controller may fail. If the F60 is to be used in areas where low temperatures will be encountered, always lag the pipework for several metres either side of the controller and also lag the base of the controller to prevent the unit and any adjacent pipework from freezing.

3) Do not use this controller in hot water applications. The F60 is not designed to be used in water hotter than 60°C.

4) Do not expose this controller to static or dynamic pressures greater than 20 Bars, 290 psi.

5) Do not install this pump controller in a section of pipe that is subject to vibration. Vibration will cause premature failure of the electronic components within the controller.

Operating Range	
Ambient Temperature Range	1°C to 50°C
Liquid Temperature Range	1°C to 60°C See note below
Ingress Protection Rating	IP67
Pre-Start Timer	Adjustable from 1second to 4 minutes in 1 second increments.
Start-up Timer	Adjustable from 1second to 4 minutes in 1 second increments.
Snore Timer	Adjustable from 1second to 4 minutes in 1 second increments.
Run-on Timer	Adjustable from 1 second to 15 minutes in 1 second increments.
Delayed Restarting	Adjustable from 1 minute to 99 Hours 59 minutes in 1 minute increments.
Cyclic Running	Running and stopping times both adjustable from 1 minute to 99 Hours 59 minutes in 1 minute increments.
Anti Cycling	Adjustable from 1 motor start per hour to 1800 starts per hour.
Run Dry Auto Restart (User Settable to Single or Repeated Attempts)	Adjustable from 1 minute to 99 Hours 59 minutes in 1 minute increments.
Maximum Operating Pressure Static or Dynamic	20 Bars 290 psi. See note below
Minimum Burst Pressure, all Models	> 30 Bars 435 psi
Starting Pressure Range	0 to 2000 kPa or 0 to 290 psi in steps of 1 kPa or 1 psi.
Stopping Pressure Range	0 to 2000 kPa or 0 to 290 psi in steps of 1 kPa or 1 psi.
Minimum Pressure Differential On to Off	1kPa or 1 psi. Practical limit is nominally 10kPa or 1.5 psi.
Recommended pipe size	25mm 1" or larger. (There is no upper limit).

NOTE: The F60 must NOT be used in hot water applications >60°C. The controller is rated to withstand water pressure to 20 Bars (290 psi) and must not be used in applications where the static or dynamic pressure exceeds this rating.

Electrical



WARNING

All electrical work associated with the F60 must be carried out by qualified electrical personnel and all electrical work must conform to AS/NZ standards and to local wiring rules. For mains voltage applications we recommend the supply to the F60 be isolated by an RCD that has a maximum trip current of 30mA.

Introduction

The F60 is designed to directly control single-phase pump motors to 3.75kW. No interposing contactor is required for such applications. If a supply neutral is available the controller can also be used to control 3 phase pump motors via an appropriate interposing contactor.

The F60 requires a 220V to 240V AC 50Hz supply when operated from the mains. It can also be operated from an 18 to 24V AC or DC supply by utilising the low voltage active terminal LV and common neutral terminal N (see the included wiring diagrams). When operated from a low voltage DC supply the terminals LV and neutral N are not polarity sensitive. The controller requires a stable supply voltage in order to operate correctly. Pay particular attention to cable sizes, and ensure cables are adequate for the specific pump motor load.

This is particularly important where long cable runs are to be used in the installation. If the voltage drop associated with the starting of the pump motor is excessive the F60 will automatically reset and this may cause the pump to jog. Jogging can snap the main spindle of a pump very easily, so please take all precautions to ensure the voltage supply to the F60 is stable and that the current carrying capacity of the cable is adequate for the job.

Brownout Or Blackout

If a blackout or brownout occurs the F60 pump controller will not retain any memory of where in its run or stop cycle it may have been, it will simply shut down the pump. When power resumes, the F60 will reboot, restart the pump and run any timer settings from the beginning. A manual reboot can be done at any time by simply pressing the controller's reset button.



WARNING

The F60 derives low voltage for its operation from a non-isolated reactance power supply (not through an isolated transformer). All external devices connected to the F60 controller must be earthed and must be regarded as operating at full mains potential.

Cables

The F60 has 3 X M20 cable glands. As supplied, the cable glands are blanked off. To use the glands first punch out the blanking barriers using a suitable punch. The cable glands can accept cable from 7 to 9mm diameter. See attached sketch for assembling the cable gland components. The controller is supplied with a set of steel crimp rings. The crimp rings are to provide strain relief for the controller's cables. To use the crimps, place one on the cable approximately 3 to 4mm below the end to the cable's outer sheathing. Crimp the two ears of the ring flat using bull nosed pliers. Pull the cable back through the cable gland until the crimp ring's ears are fully located into the slots in the cable gland housing.

CABLE GLAND ASSEMBLY

NOTE:

AS SUPPLIED CABLE GLANDS ARE BLANKED OFF. TO USE A CABLE GLAND FIRST PUNCH OUT THE BLANKING BARRIER

CRIMP THE EARS OF THE STRAIN RELIEF RING ONTO THE CABLE AND PULL THE CABLE BACK INTO THE SLOTS IN THE GLAND HOUSING

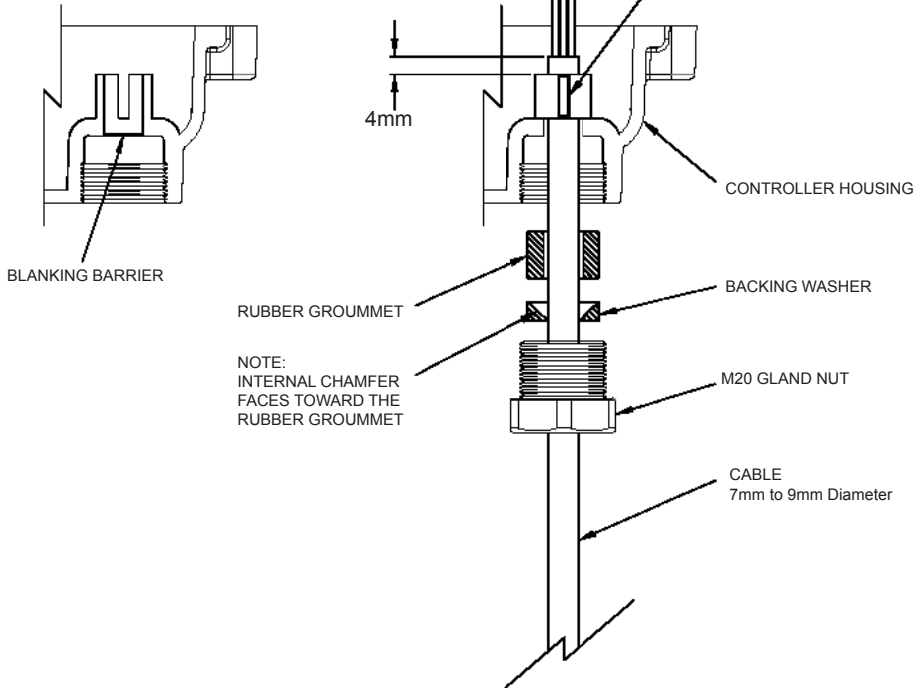

VOLTAGE LIMITS ON TERMINALS A & N

Maximum Supply Voltage	250VAC 50Hz
Minimum Supply Voltage	160VAC 50Hz

VOLTAGE LIMITS ON TERMINALS LV & N

Maximum Supply Voltage	25VAC 50Hz or 25VDC
Minimum Supply Voltage	18VAC 50Hz or 18VDC

RELAY 1 CONTACT RATING

30A at 250VAC	Resistive Load
20A at 28VDC	Resistive Load
500mA at 5VDC	Minimum Load

RELAY 2 CONTACT RATING

16A at 250VAC	Resistive Load
16A at 30VDC	Resistive Load



WARNING

Do not connect any supply greater than 25VAC or DC to the LV terminal on the F60. The LV terminal is only for use with a low Voltage supply of less than 25V AC or DC. If a Voltage greater than 25V AC or DC is connected to the LV terminal of the controller, the controller will be damaged and any warranty on the controller will be void.

Remote Input

An external switch with voltage free contacts such as a tank level switch or a set of external relay contacts can be used to either start or to start and stop a pump under the control of the F60. The supply to the external switch must be taken from the (LV) terminal (Low Voltage active terminal) of the F60 when the controller is powered from the mains or from a 24VAC source. The F60 must always be powered from the same source as the supply to external switch. The supply to the remote switch on the F60-12 (low voltage DC model) must be taken from the supply positive terminal. In all cases the external switch return wire must be connected to the Remote input (R) terminal on the F60. The Supply to the external switch will range from 12 to 24 VDC or from 20V to 35V AC depending on the model of the controller and on the supply voltage.

WARNING The low voltage source available at the LV terminal is non-isolated and in terms of insulation must be regarded as operating at full mains potential whenever the F60 is powered from the mains.

The remote switch can be installed some distance from the F60. The maximum distance is limited by cable resistance and capacitance. The total cable resistance must not exceed 5K Ohms with the remote switch closed. The total capacitance of the cable must not exceed 25nF with the remote switch open. Wires to the remote switch should be run separately from power carrying cables. Do not run the remote switch wires in a conduit that also contains power cables. Capacitive coupling between the adjacent cables may cause false triggering of the F60's remote input. For cable runs longer than 150 meters we suggest using 2 separate wires to reduce capacitive coupling between the adjacent wires. When set up this way cable resistance becomes the limiting factor for distance. The table below sets out the resistance of typical copper wire of various diameters.

Nominal Cross Section of copper wire in square millimeters	Resistance in Ohms per 1000 Meters
0.2	95.30
0.5	36.20
0.75	24.13
1.0	18.10
1.5	12.10

Note: Resistance may vary depending on the wire standard and the actual construction of the wire.

Note that the cable resistance refers to the total resistance out to the remote switch and back again, as measured at the controller across the 2 remote connection wires with the external remote switch closed.

Example

A water tank is located 2000 meters from the F60. Two separate wires each 0.2mm² are run to the remote tank (total wire length is 4000 meters). The resistance as measured across the 2 wires back at the F60 (with the tank level switch closed) is 382 Ohms. This is well under the 5,000 Ohm limit. The remote input to the F60 will operate properly provide the wires are separated by sufficient distance that the capacitance between is less than 25nF. Capacitance should be measured between the wires when the remote switch is open and it must be less than 25nF.

Remote Switch

The remote switch should be suitable for low voltage low current operation. In particular its contacts should only require a low wetting current. The current in the remote loop only runs to a few milliamperes and requires a switch that will conduct when closed under low current conditions. Mechanical microswitches with gold plated contacts or reed switches are the preferred method of controlling the remote input function. Conventional mechanical switches with exposed silver based contacts may initially function, however, over time their contacts will oxidise and the switch may not be able to conduct the small switching current. The contacts of reed switches are normally sealed in a glass tube filled with an inert gas that prevents oxidation of their contacts and therefore their contact resistance does not increase over time.

WARNING

Never connect an external power source to the (R) remote input terminal of the F60. The remote input terminal must only ever be connected to a supply that is sourced from the LV terminal on the F60 itself when the controller is powered from the mains or from the supply positive terminal when the controller is powered from a 12VDC supply.

MOST BASIC WAY TO CONNECT THE SUPPLY

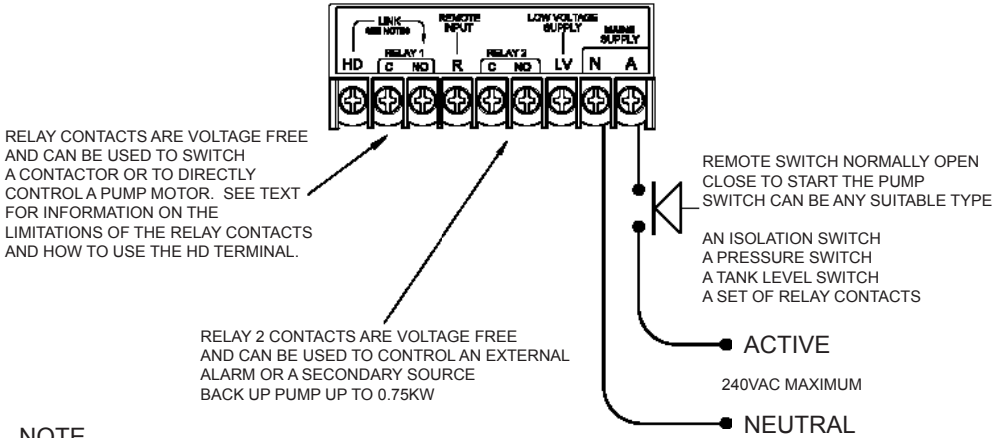

NOTE

IF THE CONTROLLER IS CONNECTED UP THIS WAY IT WILL NOT DISPLAY ANY INFORMATION ABOUT THE STATE OF THE PUMP IF THE REMOTE SWITCH IS OPEN. IT IS FAR BETTER TO HAVE A PERMANENT SUPPLY ONTO THE ACTIVE AND NEUTRAL TERMINALS AND TO CONNECT A REMOTE SWITCH TO THE LV AND R TERMINALS.

MAINS VOLTAGE EXTERNAL ALARM CONNECTIONS

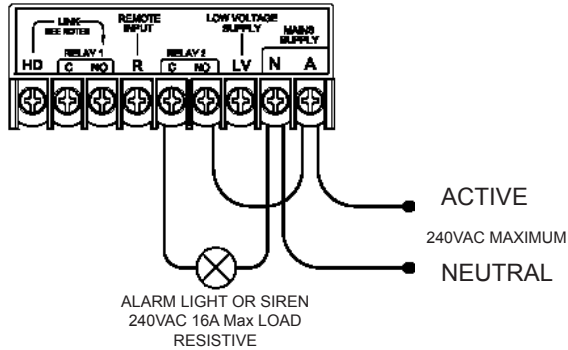

CONTROL OF A SINGLE PHASE PUMP MOTOR WITH A SECONDARY SOURCE BACK UP PUMP AND A REMOTE INPUT SWITCH

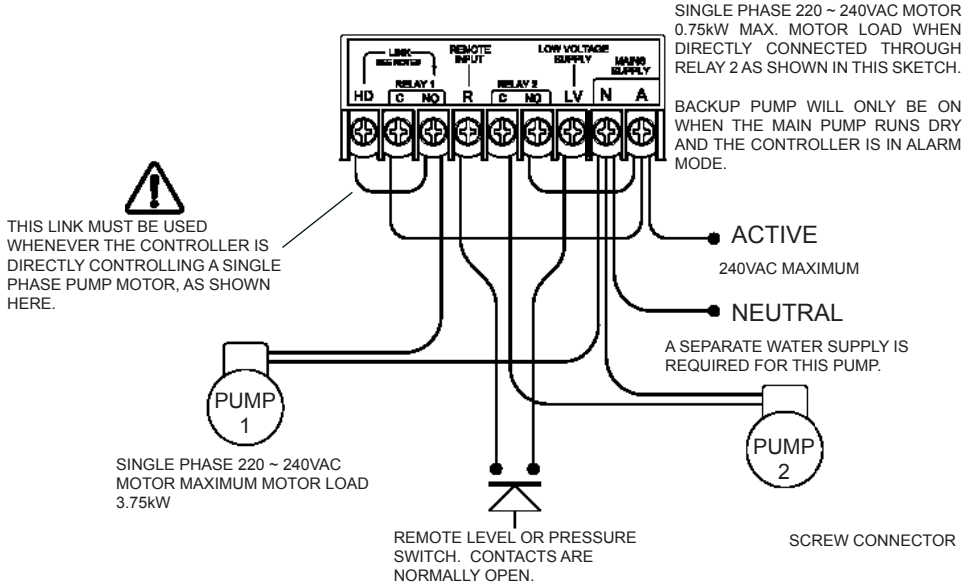

ADDITIONAL CONNECTIONS REQUIRED FOR EXTERNAL CONTROL

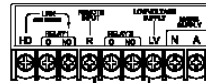

CONNECTIONS FOR PLUG & PLAY INSTALLATION

3 PIN SOCKET FOR PUMP CONNECTION 220 ~ 240 VAC 10 Amps MAXIMUM

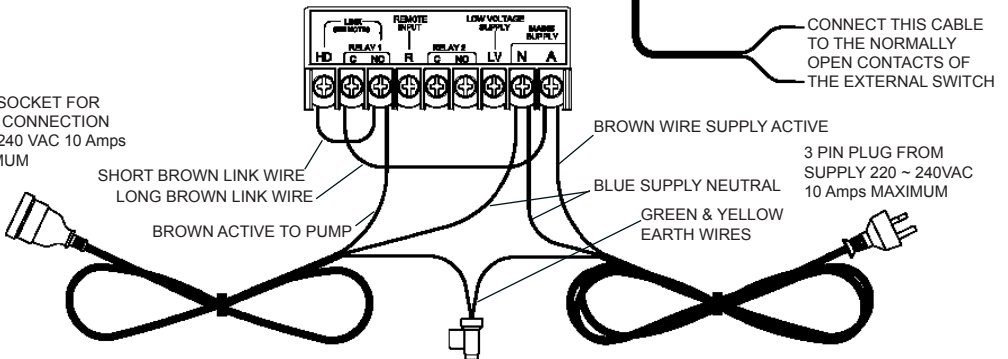

SCREW CONNECTOR COMMON EARTH CONNECTION

CONNECTIONS FOR PLUG & PLAY INSTALLATION FOR PUMP MOTORS TO 2.4 kW

LOW VOLTAGE AC CONNECTIONS WITH A REMOTE INPUT SWITCH

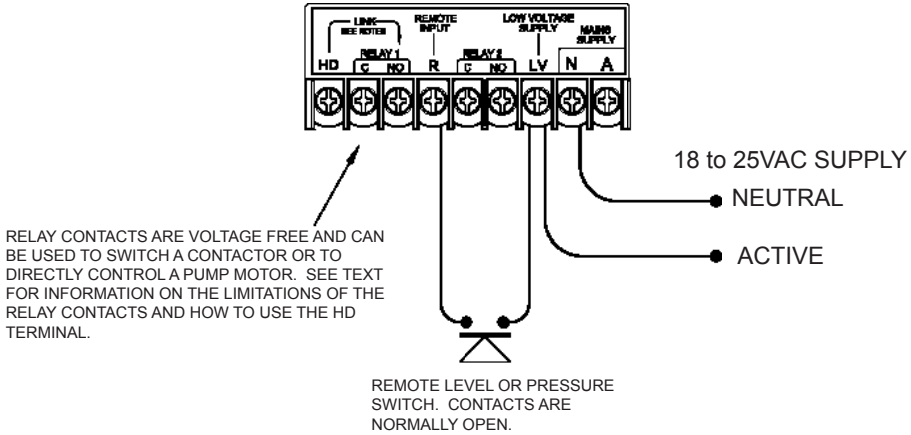

LOW VOLTAGE DC CONNECTIONS WITH A REMOTE INPUT SWITCH

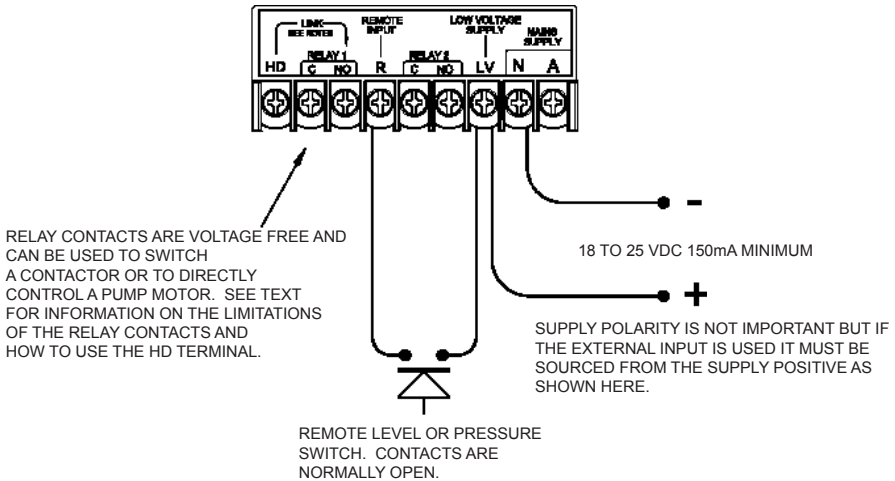

BASIC SINGLE PHASE WIRING DIAGRAM

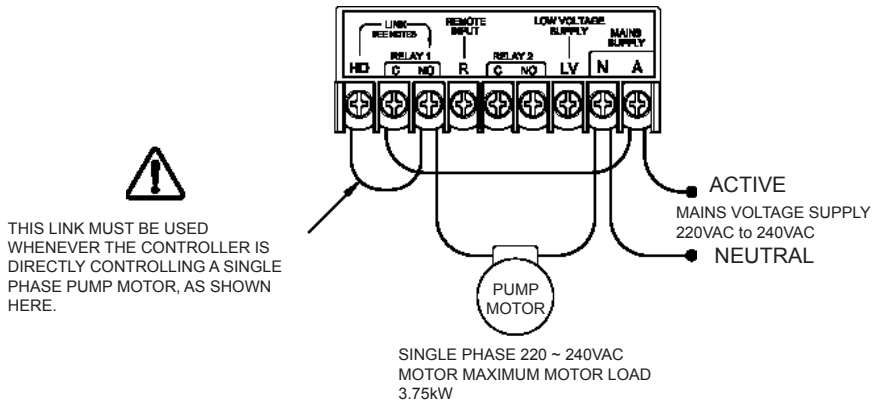

CONTROL OF A SINGLE PHASE PUMP MOTOR WITH REMOTE INPUT AND AN EXTERNAL ALARM

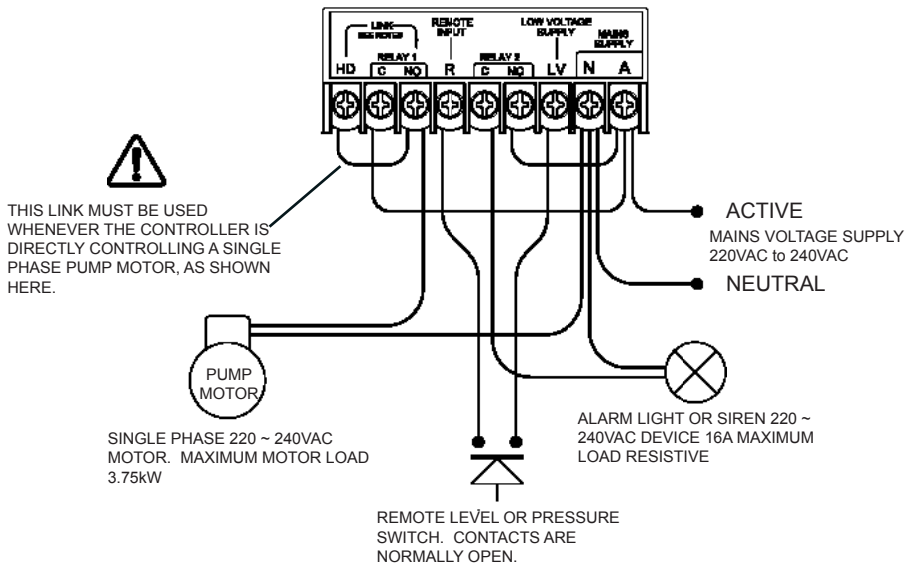

TYPICAL 3 PHASE PUMP CONNECTIONS

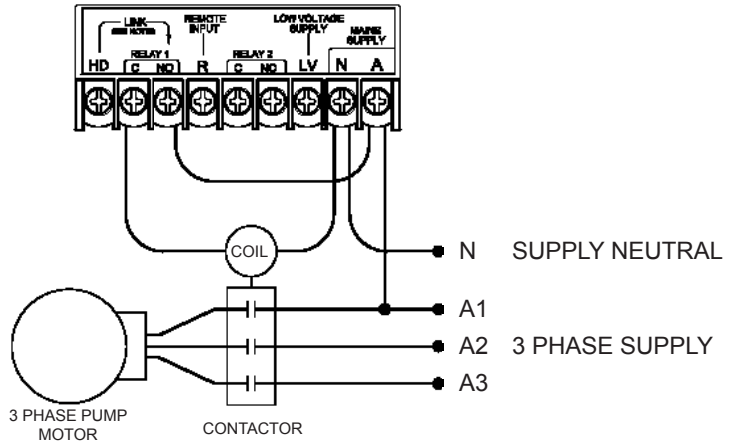

CONTROLLING A 3 PHASE PUMP WITH REMOTE INPUT AND AN EXTERNAL ALARM

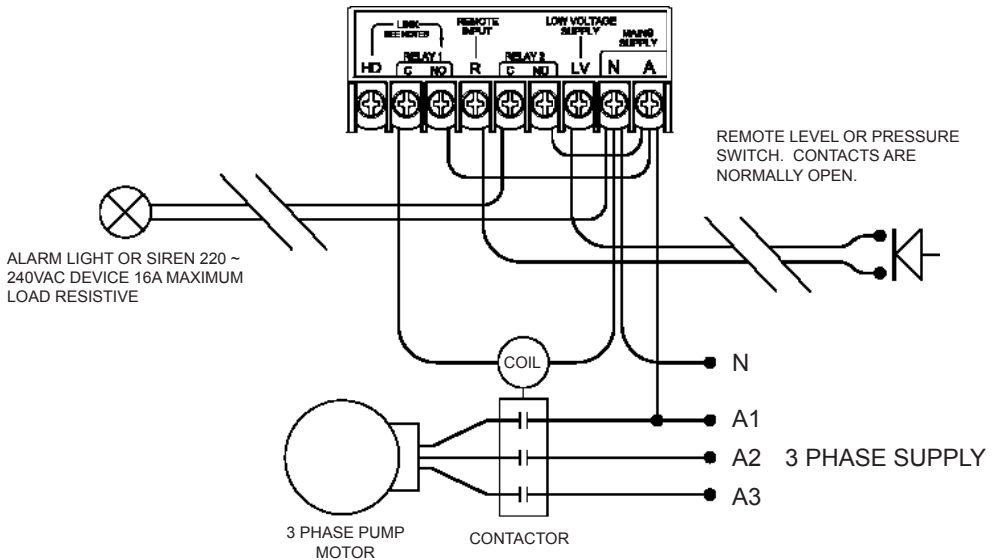

CONTROLLING A 240VAC SINGLE PHASE PUMP MOTOR WITH THE PUMP CONTROLLER POWERED FROM A LOW VOLTAGE AC SUPPLY

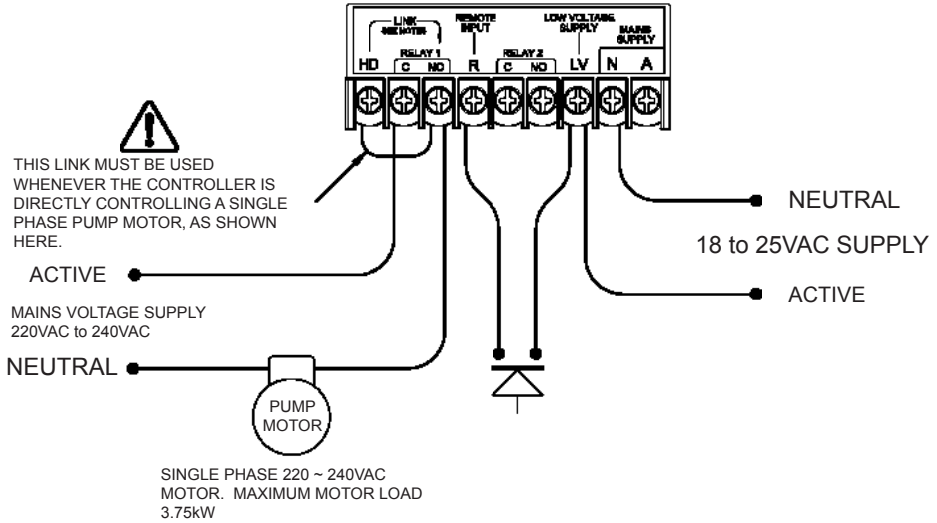

MAINS VOLTAGE REMOTE INPUT CONNECTIONS

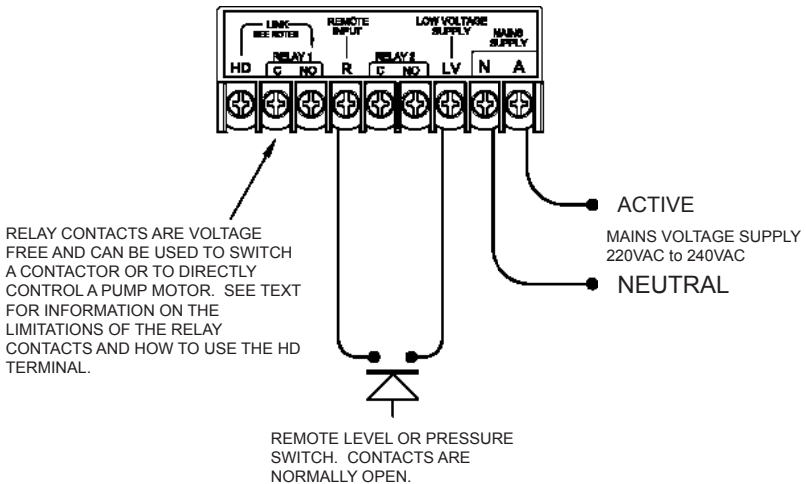

The 12VDC F60 Pump Controller

A special 12VDC version of the F60 pump controller is available for battery operation and for use in solar pumping systems. Functionally the 12V DC model is exactly the same as the mains voltage model except for the terminal block markings. On the 12VDC model the active and neutral terminals are replaced by a positive + and a negative - terminal. Supply voltage across the positive and negative terminals must never exceed 14VDC or the flow switch will be damaged. The supply terminals are reverse polarity protected however the flow switch will simply not operate unless the supply polarity is correct.

If a remote switch is connected to the 12VDC F60 the supply to the remote switch must be taken from the positive terminal on the controller. The remote switch and its connecting circuit will operate at 12VDC.

CONTROLLING A 220 ~ 240 VAC SINGLE PHASE PUMP MOTOR WITH THE PUMP CONTROLLER
POWERED FROM A 12V DC SUPPLY

WIRING DIAGRAM
12VDC CONTROLLER ONLY

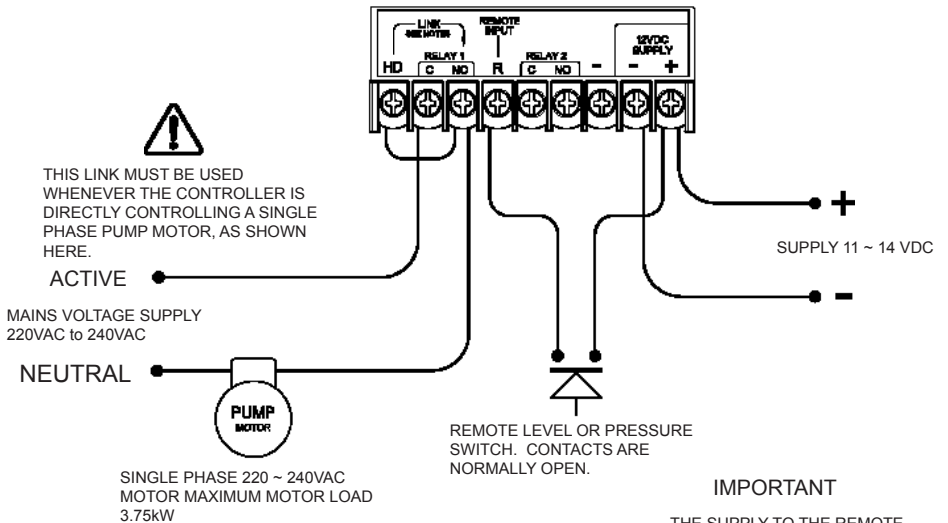

F60 Controls & their Functions

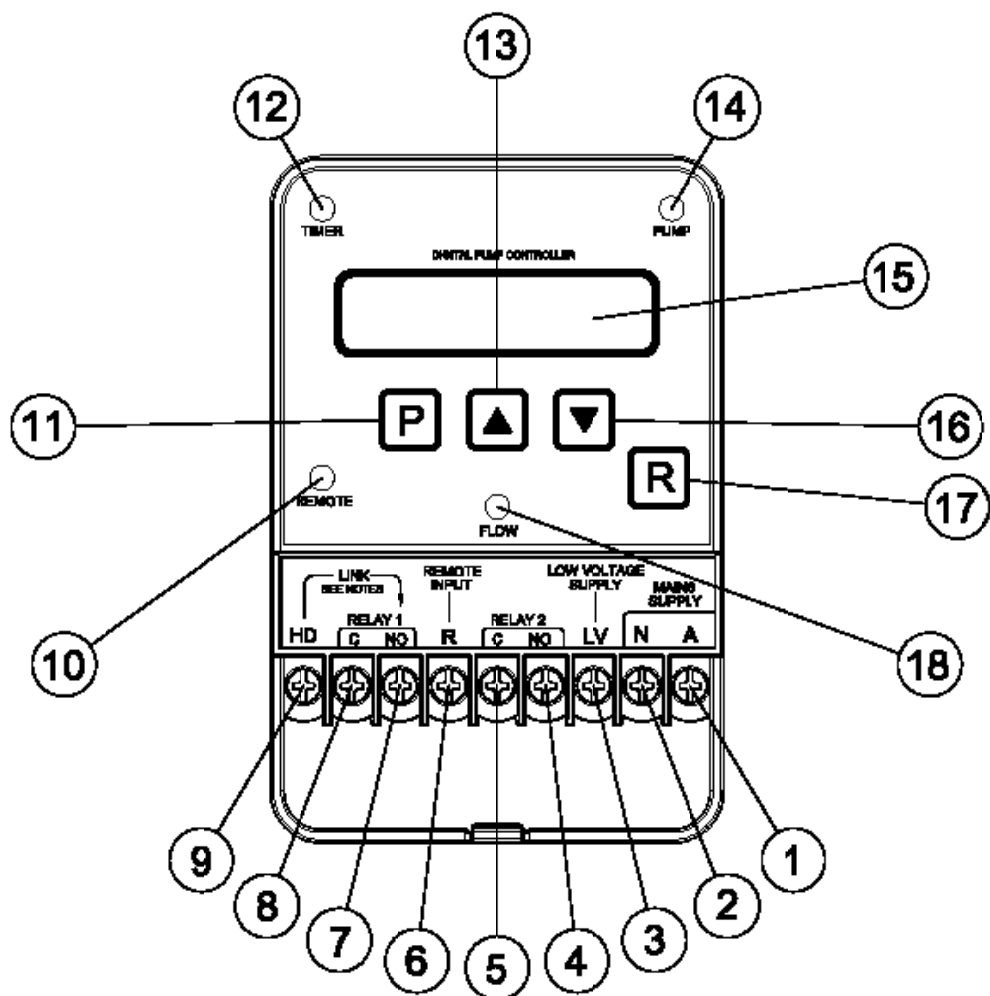

No.	Description	Function
1	Mains Voltage Active Terminal	For all mains Voltage applications this is the supply connection.
2	Supply Neutral Terminal	For all applications this is the supply neutral connection.
3	Low Voltage Active Terminal	This is the supply active terminal for all low voltage.
4	Alarm Relay Terminal Normally Open	This terminal is for connecting an external alarm, it is voltage free.
5	Alarm Relay Contact Common	This terminal is for connecting an external alarm, it is voltage free.
6	Remote Input Terminal	This is the remote switch input terminal for connection to an external switch.
7	Pump Relay Terminal Normally Open	This terminal is for connection to a pump motor or contactor
8	Pump Relay Terminal Common	This terminal is for connection to a pump motor or contactor
9	Heavy Duty Drive Terminal	Link this terminal to the relay 1 normally open terminal when directly controlling pump motors.
10	Remote Input Light (Blue)	This light is on whenever the remote input switch is closed.
11	Program Button	Press this button to program the controller.
12	Timer Light (Red or Green)	This light is green whenever a running timer is running. It turns red whenever a stop timer is running.
13	Up Button	Use This button when programming the flow switch to enter data.
14	Pump Start Light (Red or Green)	This light is red whenever the pump is stopped and it is green whenever the pump is running
15	LCD Screen	The LCD screen displays information whenever the flow switch is switched on.
16	Down Button	Use this button when programming the flow switch to enter data or to turn on the LCD backlight.
17	Reset Button	This button reboots the flow switch each time it is pressed.
18	Flow Status Light (Red or Green)	This light is green whenever flow is detected and red when no flow is detected.

Maintenance

The F60 is a low maintenance device. If it is correctly installed in a location that is out of direct exposure to the elements it should give a long and reliable life and require no maintenance at all.

Factors that may reduce its life are lightning strikes or power surges, failure to fully tighten its lid and cable glands, exposure to pressures or temperatures in excess of its ratings and operation outside its electrical limitations in terms of supply voltage and motor loads.

Spare Parts

Spare paddles are available for the F60 pump controller from your supplier.

Warranty

The F60 is warranted against faulty workmanship and materials for a period of 12 months from the date of purchase. Our complete warranty statement can be downloaded from :

<http://www.kelco.com.au/menu/information/warranty-statement>

If a warranty issue arises with this product contact your supplier or Kelco Engineering Pty Ltd. You will be issued with a returns goods authorisation number. The RGA number and proof of purchase must accompany any goods returned to us under warranty.



WARNING

If the F60 Pump Controller is used in a manner not specified by the manufacturer the pump protection provided by the controller may be impaired or negated. In addition, all warranties stated or implied may be rendered invalid.

Designed and Manufactured in Australia by

KELCO Engineering Pty Ltd

A.B.N. 20 002 834 844

Head Office and Factory: 9/9 Powells Road Brookvale 2100 Australia

Postal Address: PO Box 496 BROOKVALE NSW 2100

Phone: +61 2 99056425 Fax: +61 2 99056420 Email: sales@kelco.com.au

Web: www.kelco.com.au

PLEASE NOTE: Kelco Engineering Pty Ltd reserves the right to change the specification of this product without notice. Kelco Engineering Pty Ltd accepts no liability for personal injury or economic loss as a consequence of the use of this product. All rights reserved copyright Kelco Engineering Pty Ltd © 2013

