

# DUPLEX II

## DUPLEX II SERIES PUMPS

The Duplex II series of pumps incorporate the best technology and features developed by FLOJET. Everything from the back flow preventer, check valves, bearings and diaphragm assembly to the motor, have been designed to make this truly the most advanced and reliable diaphragm pump available. Higher efficiency of the pump is evident in the longer life of the motor pump unit. The new diaphragm design combined with the new valves makes the pump capable of pulling higher dry vacuum. Duplex II is available in various performance ranges, voltages and with a choice of elastomers, making it easily adaptable to a diverse range of applications.

### SPECIAL FEATURES

- Self priming up to 8 feet (2.4 m).
- Can run dry without damage.
- Chemical resistant material.
- Internal bypass standard.
- Built-in back flow preventer.
- Heavy duty ball bearing drive system.
- UL, CSA and CE models available.

### SPECIFICATIONS

Pump: Positive Displacement two piston design
Flow Rate: 2.2 GPM (8.32 L/min) for high pressure models 1.6 GPM (6.05 L/min) for medium and low pressure models
Pressures: Up to 100 PSI (6.89 bar)
Ports: 3/8" NPT female
Motor: Permanent Magnet with solid state rectifier
Voltages: 12 & 24 V DC, 115 & 230 V AC
Cycle: 50/60 hertz for AC models
Dry Vacuum: Up to 8 feet (2.4 M)
Pressure Switch Setting: 15, 30, 45, 60, 80, and 100 PSI
Wetted Parts: Polypropylene, Viton®, Buna or EPDM
Net Weight: 4 to 5 lbs. (2.28 kgs)
Maximum Operating Pressure: 100 PSI (6.8 bar)



### DIMENSIONS inches (mm)

#### Demand Pump

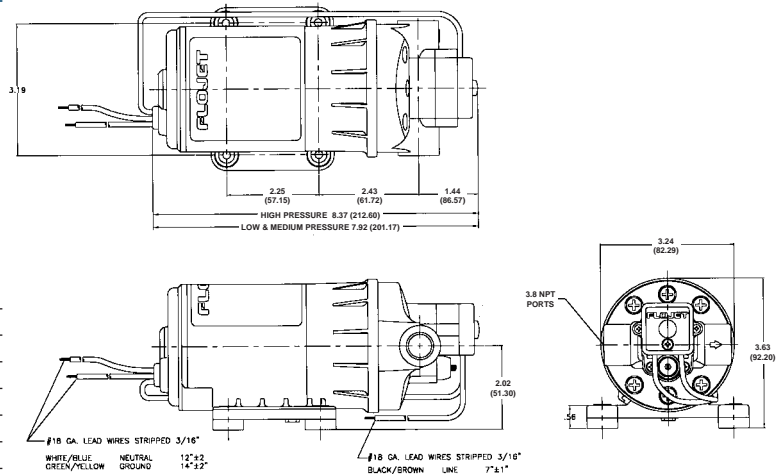

#### Bypass Pump

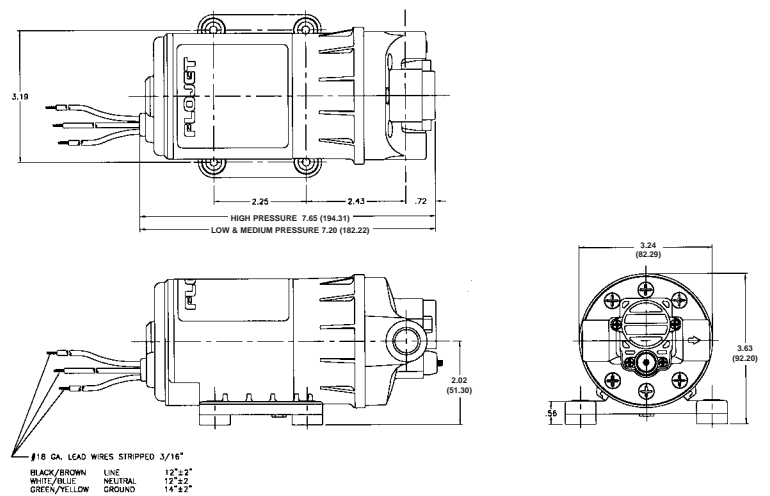

# DUPLEX II

To choose a pump model number, fill in the desired voltage code for 'x' and the compatible elastomers code for 'y'. Hence, for a medium pressure demand pump where a 115 V AC motor is required and Viton is chosen, the model number becomes D3631V5011.

Duplex II Standard Models								
Low Pressure (Up to 40 psi)	Demand Pump	D3	_____	21*	_____	3011 (Reference Curve #1)		
			(x)		(y)			
	Bypass Pump	D3	_____	21*	_____	1211 (Reference Curve #2)		
			(x)		(y)			
Medium Pressure (Up to 60 psi)	Demand Pump	D3	_____	31*	_____	5011 (Reference Curve #3)		
			(x)		(y)			
	Bypass Pump	D3	_____	31*	_____	1311 (Reference Curve #4)		
			(x)		(y)			
High Pressure (Up to 100 psi)	Demand Pump	D3	_____	35	_____	7011 (Reference Curve #5)		
			(x)		(y)			
	Bypass Pump	D3	_____	35	_____	1411 (Reference Curve #6)		
			(x)		(y)			
		x	_____	1 for 12 VDC		y	_____	V for Viton® Check Valves and Viton® Diaphragm (Viton not available in high pressure diaphragm pump)
				6 for 115 VAC, 50/60 HZ				B for Buna Check Valves and Buna Diaphragm
				7 for 230 VAC, 50/60 HZ				E for EPDM Check Valves and EPDM Diaphragm
				(See 230 V Notes)				
<p>Note: All 230 V pumps have CE mark and full RFI suppression. This is denoted by the "RL" suffix in the model number.            Contact Flojet for 230 V pumps with partial and no suppression.            * Replace "1" with "2" for 230 V pumps.</p>								

