

# CHI, CHIU

Multipurpose stainless steel pumps  
50/60 Hz



# Contents

## Product data

Introduction	3
Applications	3
Pumped liquids	4
Maximum operating pressure and temperatures	4
Performance range, 50 Hz	5
Performance range, 60 Hz	5
Type keys	6
Codes	6
Pump, CHI	7
Motor, CHI	7
Materials, CHI	7
Pump, CHIU	8
Motor, CHIU	8
Materials, CHIU	8
Curve conditions	9
How to read the curve charts	9

## Technical data, 50 Hz

CHI 2, 50 Hz	10
CHIU 2, 50 Hz	11
CHI 4, 50 Hz	12
CHIU 4, 50 Hz	13
CHI 8, 50 Hz	14
CHI 12, 50 Hz	15
CHI 15, 50 Hz	16
CHI 20, 50 Hz	17

## Technical data, 60 Hz

CHI 2, 60 Hz	18
CHIU 2, 60 Hz	20
CHI 4, 60 Hz	22
CHIU 4, 60 Hz	24
CHI 8, 60 Hz	26
CHI 12, 60 Hz	28
CHI 15, 60 Hz	30
CHI 20, 60 Hz	32

## Pumped liquids

Pumped liquids	34
List of pumped liquids	34

## Variants

Lists of variants	36
WebCAPS	38
WinCAPS	39

## Introduction

The Grundfos **CHI** pumps are non-self-priming, horizontal, multistage centrifugal pumps.



GR2531 - GRA2115

Pump and motor are integrated in a compact and user-friendly design fitted to a base plate making the pumps suitable for installation in compact systems.

The pump is made of corrosion-resistant materials and thus ideally suited for water supply and a wide range of applications in industry, agriculture and in the food industry.

CHI pumps have many incorporated advantages such as those mentioned below.

### Worldwide usage

- Different certificates and approvals like UL/CSA for America and Canada.
- Different voltage and frequency combinations.
- State-of-the-art shaft seal materials (silicon carbide SiC-G) offering these benefits:
  - high wear resistance and long operating times
  - reduced risk of sticking if the liquid contains glycol
  - improved dry-running properties due to the graphite content of the SiC.

### Customized solutions

See Lists of variants on page 36.

- Motor adaptation.
- Pump body modifications.

**CHIU** pumps are horizontal, multistage centrifugal pumps of the canned rotor type, i.e. pump and motor form an integral unit without shaft seal. The pumps are made of stainless steel, and the bearings are lubricated by the pumped liquid.



GR7259

CHIU pumps have many incorporated advantages such as those mentioned below.

### Low noise level

- No noise from the fan due to the liquid-cooled motor means a very low noise level.

### Worldwide usage

- Different certificates and approvals like UL/CSA for America and Canada.
- Different voltage and frequency combinations.

### Customized solutions

See Lists of variants on page 36.

- Pump body modifications.
- Modifications for R134a refrigerants.

## Applications

The CHI and CHIU pumps are primarily designed for industrial applications.

Typical applications	CHI	CHIU
Water treatment	●	○
Industrial washing and dish-washing machines	●	○
Pressure boosting of process water	●	
Heating and cooling in industrial processes	●	○
Air-conditioning	●	○
Air washing, moisturisation and humidification (softened water)	●	●
Water supply and pressure boosting (potable water, also slightly chlorinated)	●	●
Fertilizer/dosing systems	●	○
Aquafarming	●	

In addition, the CHI, CHIU pump is suitable for many special applications.

● Recommended

○ Applicable

## Pumped liquids

CHI, CHIU pumps are suitable for thin, clean and non-explosive liquids without solid particles or fibres.

The pumps are able to pump liquids such as demineralised water, softened water, cleaning solutions and light oils.

When pumping liquids with a density and/or viscosity higher than those of water, motors with correspondingly higher outputs must be used, if required.

WinCAPS can be used for the calculation of motor output when anti-freeze additives are used.

Whether a pump is suitable for a particular liquid depends on a number of factors of which the most important are chloride content, pH value, temperature and content of solvents, oils.

## Maximum operating pressure and temperatures

The actual operating range depends on the operating pressure, the pump type, the type of shaft seal, the pumped liquid and the liquid temperature.

### Temperatures

O-ring material/liquid	Temperature
EPDM	- 20 °C + 120 °C
FKM / liquids containing water	- 20 °C + 90 °C
Liquid	- 10 °C
FKM / oil without water	+ 120 °C
FKM / oil without water (where cUL and CSA approvals are required)	- 20 °C + 110 °C
Ambient temp. At a relative air humidity of maximum 95 %	- 20 °C + 40 °C
Storage	- 30 °C + 55 °C

**Maximum operating pressure:** 10 bar.

**Maximum inlet pressure** is limited by the maximum operating pressure.

### Shaft seal

Select the shaft seal on the basis of liquid temperature and type of liquid.

For other liquids than water, the chemical resistance of the materials, including seal face, seat and rubber components of the shaft seal, must be taken into account.

The following table shows the available shaft seal types.

Pump type	Shaft seal type	Material	Rubber parts
CHI	BUBE	Tungsten carbide (U)	EPDM (E) FKM (V)
	BUBV	Tungsten carbide (U)	
	BQQE	Silicon carbide (Q)	
	BQQV	Silicon carbide (Q)	
CHI	BQQE	Silicon carbide (Q)	
	BQQV	Silicon carbide (Q)	
CHIU	No shaft seal		

The following curves apply to clean water and water containing antifreeze additives.

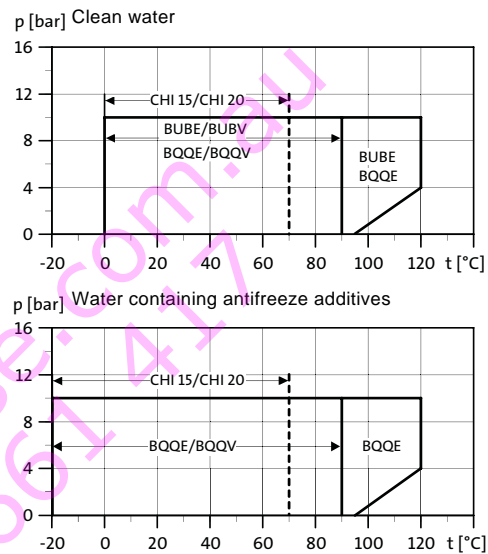

**Fig. 1** Curves for the selection of shaft seals

The silicon carbide shaft seal, for instance BQQE, has excellent qualities in liquids containing anti-freeze additives. Furthermore, it is less sensitive to short-time dry running.

**Note:** Dry running must always be avoided.

TM01 8936 3806

## Performance range, 50 Hz

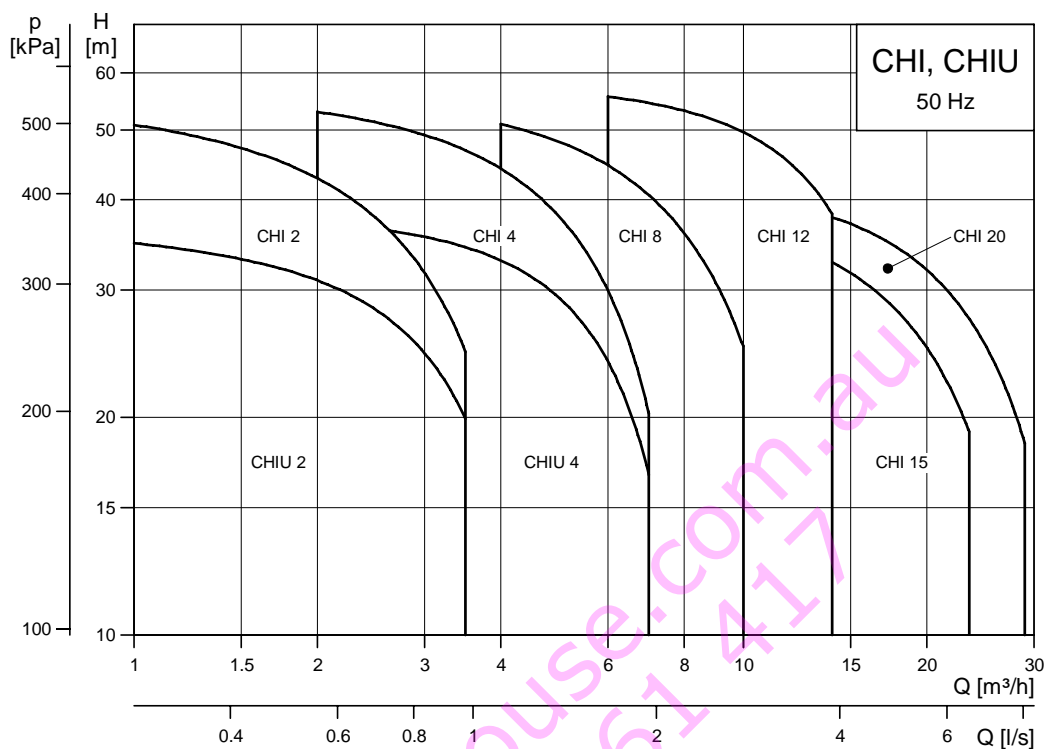

Fig. 2 Combined curves, 50 Hz

## Performance range, 60 Hz

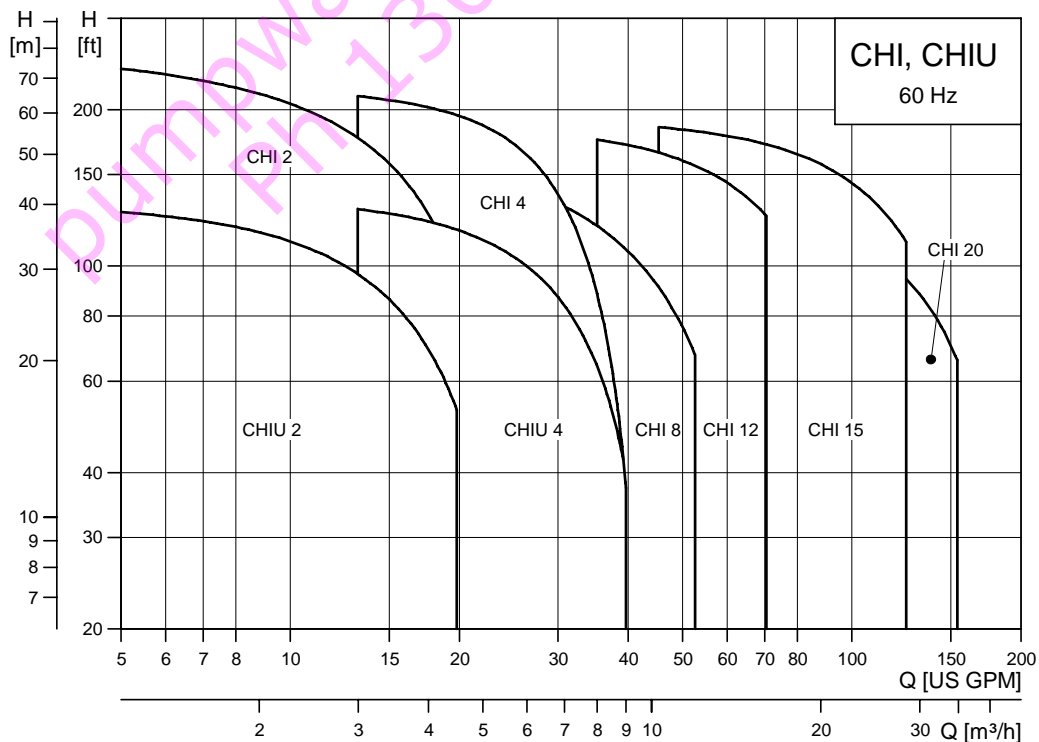

Fig. 3 Combined curves, 60 Hz

TM02 6720 1806

TM02 6330 1806

## Type keys

### CHI

Example	CHI	4	-	50	-	A	-	W	-	G	-	BQ	E
Type range													
Nominal flow rate [m <sup>3</sup> /h]													
Number of stages x 10													
Code for pump version													
Code for pipe connection													
Code for materials excl. plastic and rubber parts													
Code for shaft seal													

### CHIU

Example	CHI	U	4	-	40	-	A	-	W	-	G	-	E
Type range													
Canned rotor type													
Nominal flow rate [m <sup>3</sup> /h]													
Number of stages x 10													
Code for pump version													
Code for pipe connection													
Code for materials excl. plastic and rubber parts													
Code for rubber parts in pump													

## Codes

Example	A	-W	-G	-E	-B	U	B	E
<b>Pump version</b>								
A Basic version								
<b>Pipe connection</b>								
W Internal thread								
B NPT thread								
N Connecting thread, special								
<b>Materials</b>								
G Parts of stainless steel 1.4401 or similar class								
X Special version								
<b>Code for rubber parts in pump, CHIU</b>								
E EPDM								
V FKM								
<b>Shaft seal, CHI</b>								
B Rubber bellows seal								
U Tungsten carbide								
Q Silicon carbide								
A Carbon, metal-impregnated								
B Carbon, resin-impregnated								
E EPDM								
V FKM								

## Pump, CHI

The pumps are made of stainless steel and have a maintenance-free mechanical shaft seal with dimensions according to DIN 24960.

The pump is compact with small physical dimensions, axial suction port and radial discharge port.

Connections	CHI 2	CHI 4	CHI 8	CHI 12	CHI 15	CHI 20
Axial suction port	Rp 1	Rp 1¼	Rp 1½	Rp 1½	Rp 2	Rp 2
Radial discharge port	Rp 1	Rp 1¼	Rp 1½	Rp 1½	Rp 2	Rp 2

## Motor, CHI

The pump is coupled with a TEFC (totally enclosed, fan-cooled) Grundfos squirrel-cage motor.

Standard voltages: 1 x 220-240 V, 50 Hz  
 3 x 220-240/380-415 V, 50 Hz  
 1 x 115/230 V, 60 Hz  
 3 x 208-230/440-480 V, 60 Hz  
 3 x 575 V, 60 Hz

Voltage tolerance: + 6 %/– 10 %

Frequency tolerance: ±0.5%

Electrical tolerances according to EN 60034.

Enclosure class: IP 55

Insulation class: F

Sound-pressure level: ≤64 dB(A).

Cable connection: M20 x 1.5 according to EN 50262  
 (For Japan MG71/MG80 motors:  
 Pg 16 thread according to DIN 40430)

The single-phase motors are supplied with a built-in thermal relay to IEC 34-11. TP 211 (slow overload as well as locked rotor). The motors require no further motor protection.

**Note:** Single-phase motors with UL approval (1 x 115/230 V, 60 Hz) do not have built-in motor protection and therefore require external motor protection.

The three-phase motors do not incorporate thermal protection and therefore require external motor protection in accordance with local regulations.

The **sound pressure** level of the pump is lower than the limiting values stated in the EC Council Directive 98/37/EC relating to machinery.

### Frequency converter operation

Most three-phase motors can be operated with a frequency converter. See Lists of variants on page 36.

## Materials, CHI

Pos.	Description	Materials	EN/DIN
1	Pump sleeve	Stainless steel	1.4401
2	Intermediate chamber/ guide vanes	Stainless steel	1.4401
3	Impeller	Stainless steel	1.4401
4	Suction interconnector	Stainless steel	1.4401
5	Splined shaft	Stainless steel	1.4401
6	Cover plate	Stainless steel	1.4401
7	Seal faces	BUBE, BUBV, BQQE, BQQV	
8	Base plate	Painted steel	1.0338
9	Motor flange	Cast iron Silumin	EN-JL1040
10	Ball bearing		
	O-rings	EPDM or FKM	

## Sectional drawing, CHI

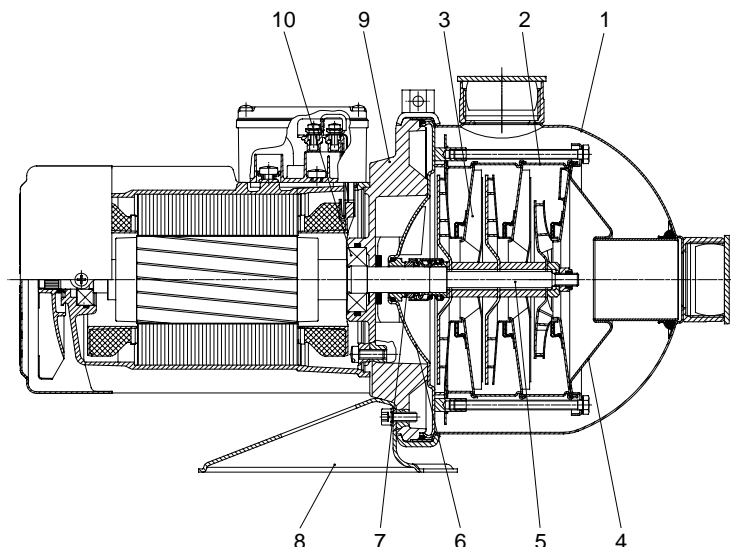

Fig. 4 Sectional drawing, CHI

TM00 0464 3897

## Curve conditions

The guidelines below apply to the curves shown on the following pages:

1. Tolerances to ISO 9906, Annex A, if indicated.
2. Measurements were made with airless water at a temperature of 20°C.
3. The curves apply to a kinematic viscosity of  $\nu = 1 \text{ mm}^2/\text{s}$  (1 cSt).
4. The bold curves indicate the **recommended** performance range. The thin curves are only a **guide**.
5. Due to the risk of overheating, the pumps should **not** be used at a flow below the minimum flow rate.

The curve below shows the minimum flow rate as a percentage of the nominal flow rate in relation to the liquid temperature.

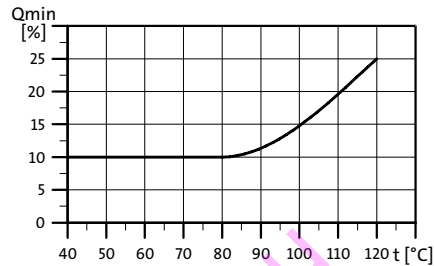

Fig. 6 Minimum flow rate

TM01 9158 1503

## How to read the curve charts

### Curves

- QH: Pump performance at actual speed.
- $P_2$ : Pump input power.
- Eta 1: Total efficiency, i.e. pump with motor, is shown in the curve charts as Eta 1.
- NPSH: Average values for all variants shown in chart 1. When sizing, make a safety allowance of at least 0.5 m.

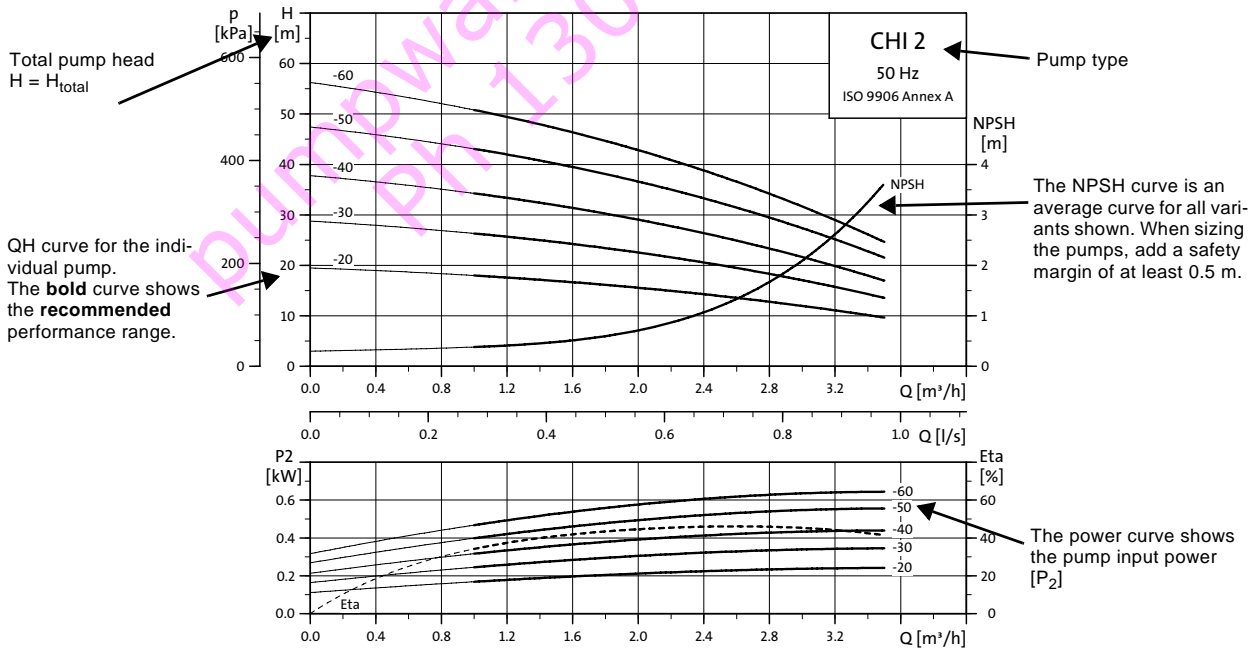

TM00 4347 2400

## CHI 2, 50 Hz

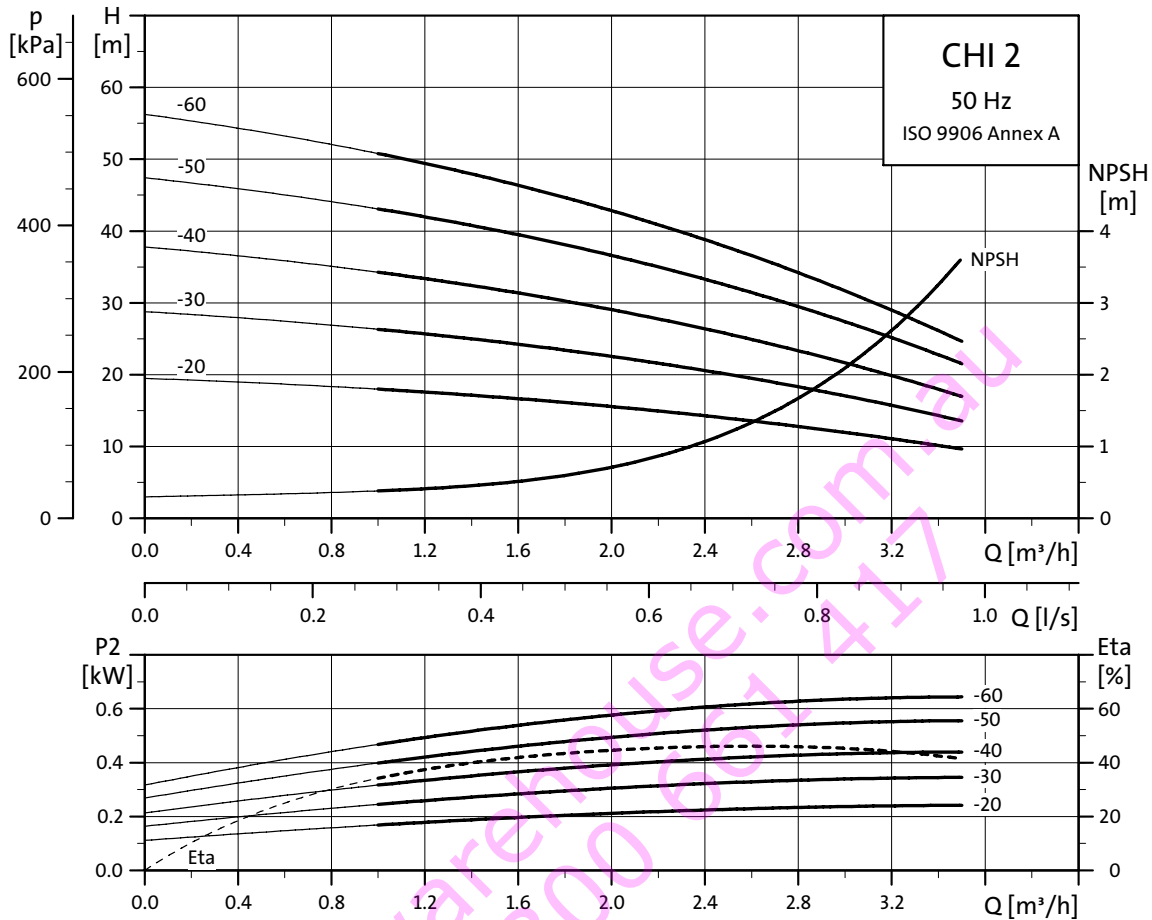

## Dimensions and weights

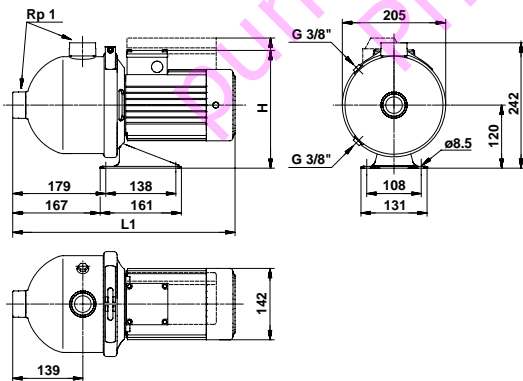

Pump type	Dimensions [mm]				Net weight [kg]
	1-phase		3-phase		
	L1	H	L1	H	
CHI 2-20	397	253	397	229	9.6
CHI 2-30	397	253	397	229	9.9
CHI 2-40	397	253	397	229	10.1
CHI 2-50	397	253	397	229	10.8
CHI 2-60	397	253	397	229	11.0

## Electrical data

1 x 220-240 V, 50 Hz

Pump type	P <sub>1</sub> [W]	I <sub>1/I</sub> [A]	n [min <sup>-1</sup> ]
CHI 2-20	450	1.9-2.4	2920
CHI 2-30	540	2.4-2.6	2880
CHI 2-40	640	2.9-2.9	2850
CHI 2-50	800	3.6-3.5	2850
CHI 2-60	940	4.4-4.0	2820

3 x 220-240Δ/380-415Y V, 50 Hz

Pump type	P <sub>1</sub> [W]	I <sub>1/I</sub> [A]	n [min <sup>-1</sup> ]
CHI 2-20	350	1.5/0.8	2940
CHI 2-30	480	1.7/1.0	2910
CHI 2-40	620	1.9/1.1	2885
CHI 2-50	820	2.6/1.5	2885
CHI 2-60	950	2.8/1.6	2860

## CHI 4, 50 Hz

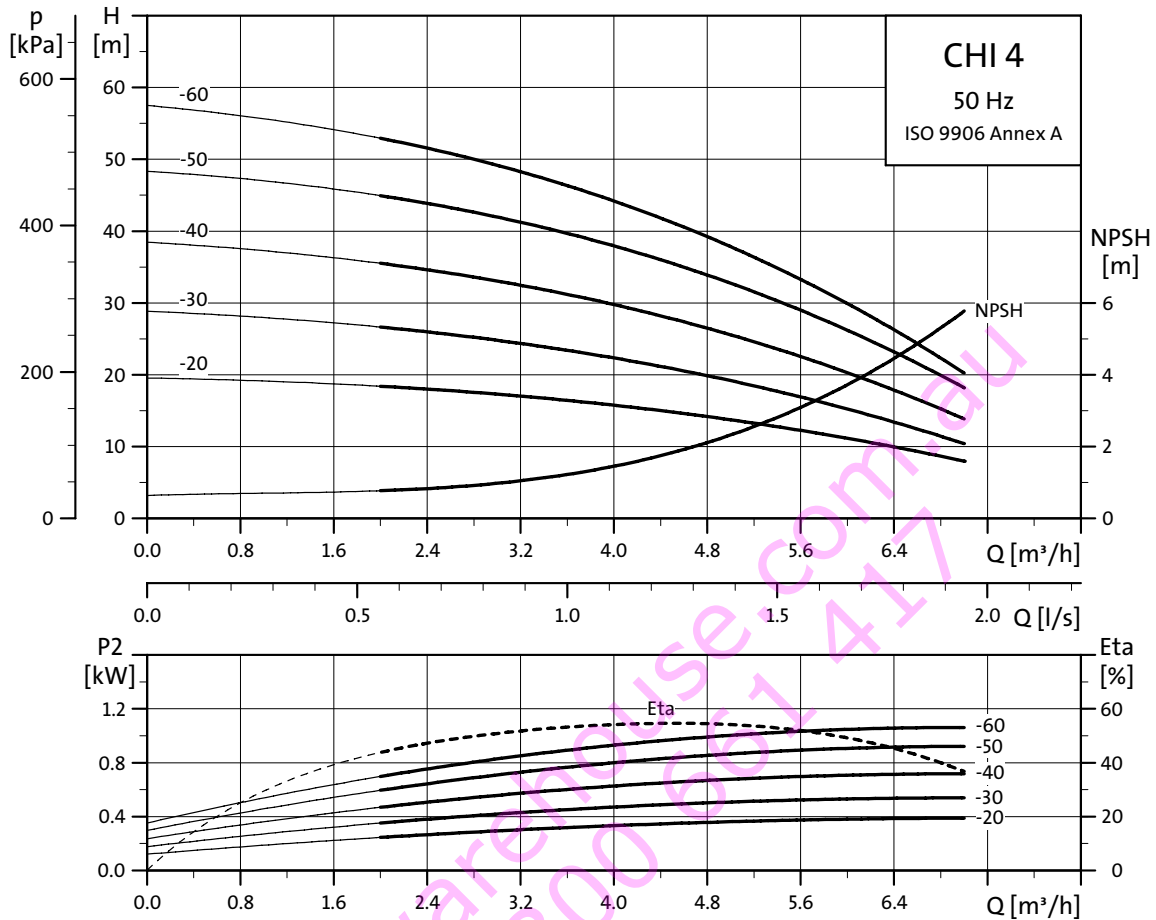

## Dimensions and weights

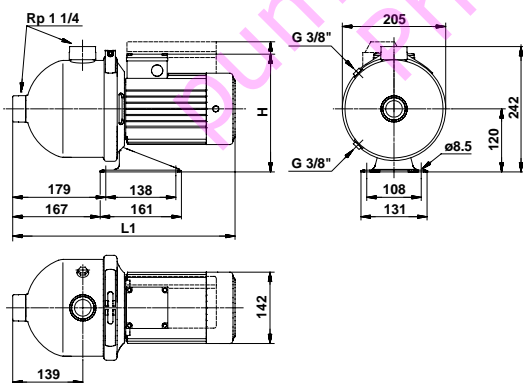

Pump type	Dimensions [mm]				Net weight [kg]
	1-phase		3-phase		
	L1	H	L1	H	
CHI 4-20	397	253	397	229	9.6
CHI 4-30	397	253	397	229	9.9
CHI 4-40	397	253	397	229	10.6
CHI 4-50	437	253	437	229	12.1
CHI 4-60	437	253	437	229	12.3

## Electrical data

### 1 x 220-240 V, 50 Hz

Pump type	P <sub>1</sub> [W]	I <sub>1/1</sub> [A]	n [min <sup>-1</sup> ]
CHI 4-20	590	2.6-2.7	2885
CHI 4-30	820	3.7-3.6	2830
CHI 4-40	1040	4.9-4.5	2860
CHI 4-50	1420	6.6-5.7	2830
CHI 4-60	1510	7.1-6.8	2850

### 3 x 220-240Δ/380-415Y V, 50 Hz

Pump type	P <sub>1</sub> [W]	I <sub>1/1</sub> [A]	n [min <sup>-1</sup> ]
CHI 4-20	550	1.8/1.0	2900
CHI 4-30	800	2.4/1.4	2870
CHI 4-40	1080	3.2/1.8	2860
CHI 4-50	1330	4.0/2.3	2870
CHI 4-60	1630	4.8/2.7	2850

## CHI 8, 50 Hz

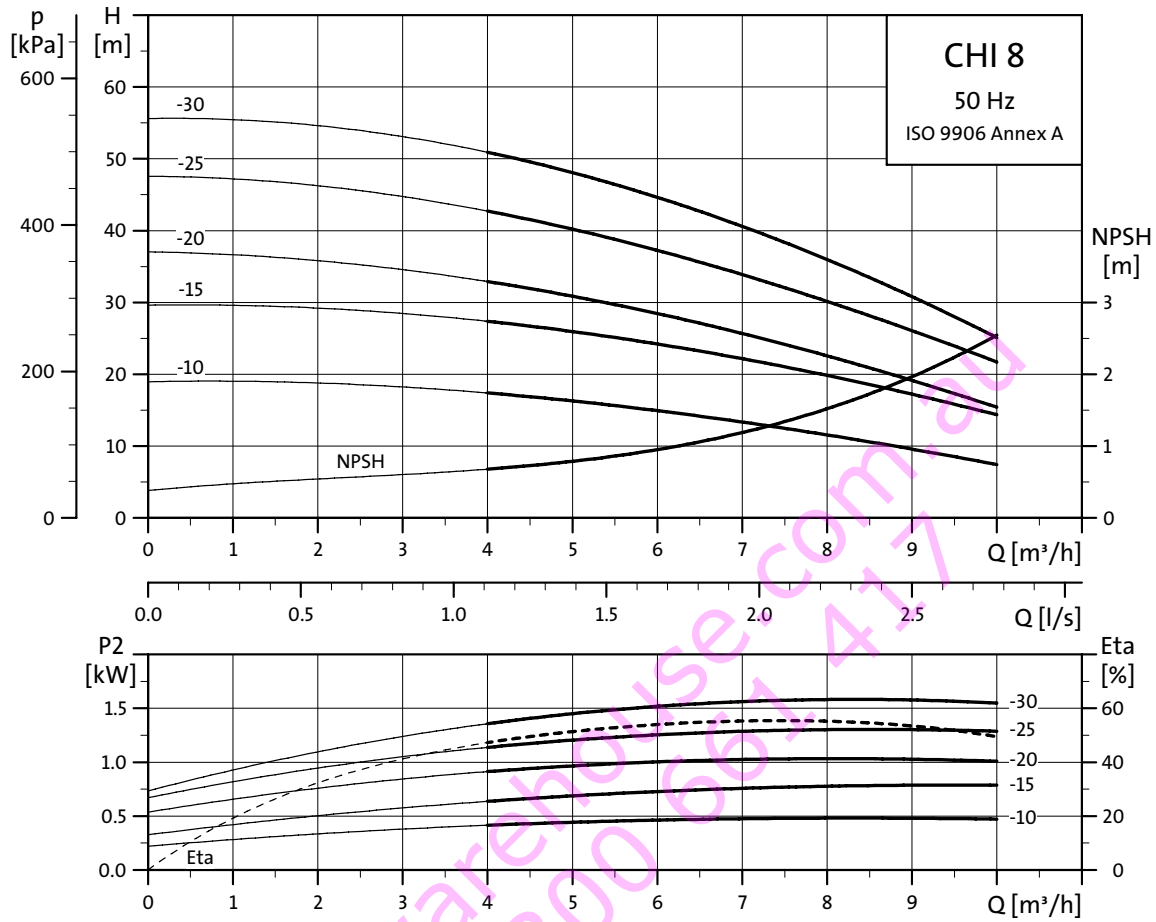

TM00 4351 2400

## Dimensions and weights

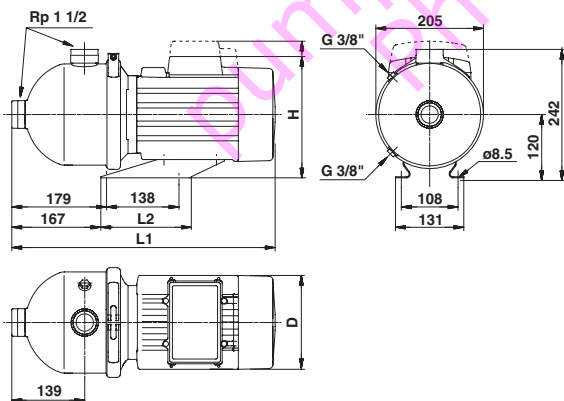

TM00 0466 2001

Pump type	Dimensions [mm]				Net weight [kg]
	L1	D	H		
			1-phase	3-phase	
CHI 8-10	397	142	229	229	10.5
CHI 8-15	437	142	229	229	12.1
CHI 8-20	437	142	229	229	13.7
CHI 8-25	500	142	259	229	14.3
CHI 8-30	500	178	259	230	21.4

## Electrical data

1 x 220-240 V, 50 Hz

Pump type	P <sub>1</sub> [W]	I <sub>1/1</sub> [A]	n [min <sup>-1</sup> ]
CHI 8-10	730	3.1-3.2	2840
CHI 8-15	1040	4.9-4.5	2750
CHI 8-20	1350	6.2-6.2	2800
CHI 8-25	1860	8.6-8.3	2815
CHI 8-30	2230	10.6-9.2	2820

3 x 220-240Δ V/380-415Y V, 50 Hz

Pump type	P <sub>1</sub> [W]	I <sub>1/1</sub> [A]	n [min <sup>-1</sup> ]
CHI 8-10	720	2.4/1.4	2875
CHI 8-15	1090	3.3/1.9	2835
CHI 8-20	1370	5.3/3.1	2880
CHI 8-25	1730	5.8/3.4	2830
CHI 8-30	2080	6.5/3.7	2890

## CHI 12, 50 Hz

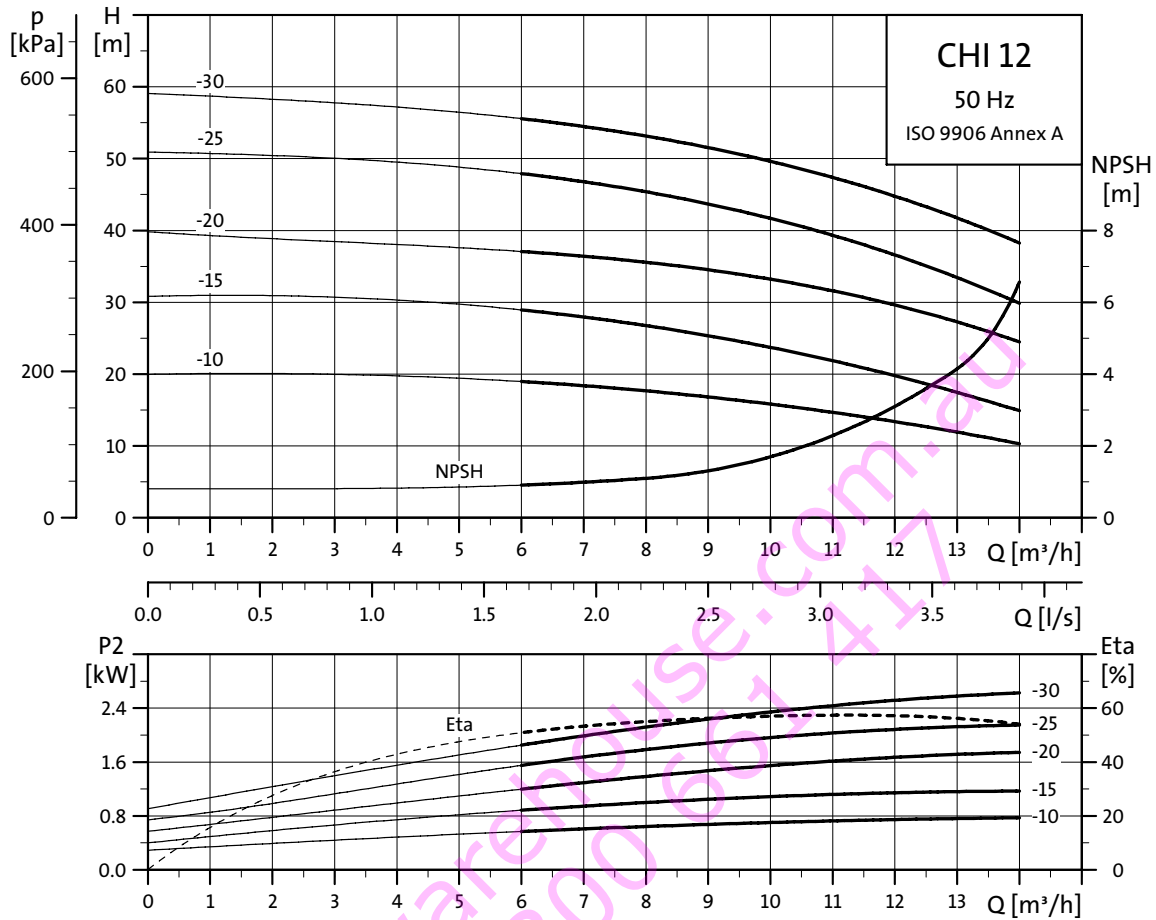

## Dimensions and weights

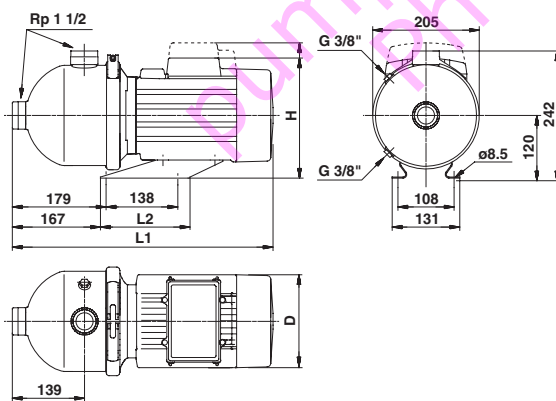

Pump type	Dimensions [mm]				Net weight [kg]
	L1	D	H		
			1-phase	3-phase	
CHI 12-10	437	142	253	229	11.8
CHI 12-15	437	142	253	229	13.5
CHI 12-20	500	178	259	230	20.9
CHI 12-25	500	178	259	230	23.9
CHI 12-30	500	178	-	230	23.9

## Electrical data

1 x 220-240 V, 50 Hz

Pump type	P <sub>1</sub> [W]	I <sub>1/1</sub> [A]	n [min <sup>-1</sup> ]
CHI 12-10	1170	5.5-4.9	2830
CHI 12-15	1600	7.5-6.9	2740
CHI 12-20	2310	10.9-10.1	2880
CHI 12-25	2800	13.7-12.4	2810

3 x 220-240Δ V/380-415Y V, 50 Hz

Pump type	P <sub>1</sub> [W]	I <sub>1/1</sub> [A]	n [min <sup>-1</sup> ]
CHI 12-10	1170	3.6/2.1	2860
CHI 12-15	1600	4.8/2.8	2820
CHI 12-20	2300	7.1/4.1	2900
CHI 12-25	2800	9.0/5.2	2890
CHI 12-30	3310	10.4/6.0	2900

## Pumped liquids

Thin, non-explosive liquids, not containing solid particles or fibres. The liquid must not chemically attack the pump materials.

When pumping liquids with a density and/or viscosity higher than those of water, oversized motors must be used, if required.

Whether a pump is suitable for a particular liquid depends on a number of factors of which the most important are the chloride content, pH value, temperature and content of chemicals and oils.

Please note that aggressive liquids (for instance seawater and some acids) may attack or dissolve the protective oxide film of the stainless steel and thus cause corrosion.

## List of pumped liquids

A number of typical liquids are listed below.

Other pump versions may be applicable, but those stated in the list are considered to be the best choices.

The table is intended as a general guide only, and cannot replace actual testing of the pumped liquids and pump materials under specific working conditions.

The list should, however, be applied with some caution as factors such as concentration of the pumped liquid, liquid temperature or pressure may affect the chemical resistance of a specific pump version.

Safety precautions must be made when pumping dangerous liquids.

### Notes

a	May contain additives or impurities which can cause shaft seal problems.
b	The density and viscosity may differ from those of water. Consider this when calculating motor and pump performance.
c	In order to avoid corrosion, the liquid must be free of oxygen. Flammable or combustible liquid.
d	Safety precautions must be considered to ensure safe handling of flammable liquids. Handling the liquid above the flashpoint and/or boiling point will require the greatest restrictions. A seal-less pump may be required. Contact Grundfos.
e	Risk of crystallization/precipitation on the shaft seal.
f	If oil residues are present, EPDM cannot be used.

Pumped liquids	Notes	Additional information	CHI 2/4/8/12	CHI 15/20
<b>Water</b>				
Boiler feed water			BQQE/BUBE	BQQE
Brackish water	a	30 °C, 2000 ppm chloride	BQQE/BUBE	BQQE
Condensate			BQQE/BUBE	BQQE
Cooling and cutting lubricant	b		BQQV	BQQV
Groundwater		< 300 ppm chloride	BQQE/BUBE	BQQE
Deminerlized water			BQQE/BUBE	BQQE
District heating water			BQQE/BUBE	BQQE
Oil-containing water			BQQV/BUBV	BQQV
Softened water			BQQE/BUBE	BQQE
Swimming pool water, chlorinated		40 °C, 150 ppm chloride, < 2 ppm free chlorine	BQQE/BUBE	BQQE
<b>Coolants</b>				
Calcium chloride	b, c, d, f	<0 °C, 30 %	BQQE	BQQE
Ethylene glycol	b, c	<50 °C	BQQE	BQQE
Glycerine (glycerol)	b, c	<50 °C	BQQE	BQQE
Hydrocarbon-based coolant	c, e	50 °C	BQQV	BQQV
Potassium acetate (inhibited)	b, c, d, f	<20 °C	BQQE	BQQE
Potassium formate (inhibited)	b, c, d, f	<20 °C	BQQE	BQQE
Propylene glycol	b, c	<50 °C	BQQE	BQQE
Sodium chloride	b, c, d, f	<0 °C, 30 %	BQQE	BQQE
<b>Fuels</b>				
Diesel oil	e		BQQV/BUBV	BQQV
Jet fuel	e		BQQV/BUBV	BQQV
Kerosene	e		BQQV/BUBV	BQQV
Naphta	e		BQQV/BUBV	BQQV
Petrol	e		BQQV/BUBV	BQQV
Biodiesel	e		BQQV/BUBV	BQQV
<b>Mineral oils</b>				
Crude oil	b, c, e	<20 °C	BQQV/BUBV	BQQV
Mineral lubricating oil	c, e		BQQV/BUBV	BQQV
Mineral motor oil	c, e		BQQV/BUBV	BQQV
<b>Synthetic oils</b>				
Synthetic lubricating oil	c, e		BQQV/BUBV	BQQV
Synthetic motor oil	c, e		BQQV/BUBV	BQQV

Pumped liquids	Notes	Additional information	CHI 2/4/8/12	CHI 15/20
Silicone oil	c		BQQV/BUBV	BQQV
<b>Vegetable oils</b>				
Corn oil	b, c		BQQV/BUBV	BQQV
Olive oil	b, c		BQQV/BUBV	BQQV
Peanut oil	b, c		BQQV/BUBV	BQQV
Rape-seed oil	b, c		BQQV/BUBV	BQQV
Soya oil	b, c		BQQV/BUBV	BQQV
<b>Cleaning</b>				
Alkaline degreasing agent	b, g	<80 °C 1)	BQQE	BQQE
Soap (salts of fatty acids)	b	<80 °C 1)	BQQV	BQQV
<b>Organic solvents</b>				
Acetone	e	40 °C	BQQE/BUBE	BQQE
Ethyl alcohol (ethanol)	e	40 °C	BQQE/BUBE	BQQE
Isopropyl alcohol	e	40 °C	BQQE/BUBE	BQQE
Methyl alcohol (methanol)	e	40 °C	BQQE/BUBE	BQQE
<b>Oxidants</b>				
Hydrogen peroxide		20 °C, 5 %	BQQE/BUBE	BQQE
<b>Salts</b>				
Ammonium bicarbonate	b, c	60 °C, 30 %	BQQE	BQQE
Copper sulphate	b, c, f	60 °C, 30 %	BQQE/BQQV	BQQE/BQQV
Ferric sulphate	b, c, f	20 °C, 30 %	BQQE/BQQV	BQQE/BQQV
Potassium bicarbonate	b, c	60 °C, 30 %	BQQE/BQQV	BQQE/BQQV
Sodium carbonate	b, c, f	60 °C, 30 %	BQQE	BQQE
Potassium permanganate	b, c	20 °C, 1 %	BQQE/BQQV	BQQE/BQQV
Sodium nitrate	b, c	60 °C, 30 %	BQQE/BQQV	BQQE/BQQV
Sodium nitrite	b, c	60 °C, 30 %	BQQE/BQQV	BQQE/BQQV
Sodium phosphate (mono)	b, c, f	60 °C, 20 %	BQQE/BQQV	BQQE/BQQV
Sodium phosphate (di)	b, c, f	60 °C, 30 %	BQQE/BQQV	BQQE/BQQV
Sodium phosphate (tri)	b, c, f	70 °C, 20 %	BQQE/BQQV	BQQE/BQQV
Sodium sulphate	b, c, f	60 °C, 30 %	BQQE/BQQV	BQQE/BQQV
Sodium sulphite	b, c, f	60 °C, 20 %	BQQE/BQQV	BQQE/BQQV
<b>Acids</b>				
Acetic acid		20 °C, 15 %	BQQE/BQQV	BQQE/BQQV
Citric acid	c	40 °C, 50 %	BQQE	BQQE
Formic acid	c	20 °C, 30 %	BQQE	BQQE
Nitric acid	c	20 °C, 5 %	BQQE/BQQV	BQQE/BQQV
Oxalic acid	f	20 °C, 1 %	BQQE/BQQV	BQQE/BQQV
Phosphoric acid	b, c, f	70 °C, 40 %	BQQE/BQQV	BQQE/BQQV
Sulphuric acid	b, c	20 °C, 1 %	BQQE/BQQV	BQQE/BQQV
Sulphurous acid		20 °C, 5 %	BQQE	BQQE
<b>Alkalies</b>				
Ammonium hydroxide		30 °C, 30 %	BQQE	BQQE
Calcium hydroxide	b	30 °C, 5 %	BQQE	BQQE
Potassium hydroxide	c, f	60 °C, 20 %	BQQE	BQQE
Sodium hydroxide	c, f	80 °C, 20 %	BQQE	BQQE

## Variants

### Lists of variants

Although the Grundfos CHI, CHIU product range offers a number of pumps for different applications, customers require specific pump solutions to satisfy their needs. Below are the options available for customizing the CHI, CHIU. Contact Grundfos for further information or for requests other than the ones mentioned below.

### Motors

<b>Motor with thermal protection</b>	Grundfos offers motors with built-in bimetallic thermal switches or temperature-controlled PTC sensors (thermistors) incorporated in the motor windings.
<b>Oversize motor</b>	In installations where one of the conditions mentioned below is present, the motor size must be evaluated to make sure there will be no risk of overload. <ul style="list-style-type: none"> <li>• Ambient temperatures above 40 °C.</li> <li>• Liquid temperatures below 0 °C.</li> <li>• Installation at an altitude of more than 1000 metres above sea level</li> <li>• Use of <b>glycol</b> or other high-viscous liquids. Alternative motors are available on request.</li> </ul>
<b>Dual-voltage motors 50/60 hz</b>	In some cases the standard product can run at dual voltage and frequency. If the standard product cannot be used for dual voltage, a bigger motor can very often be used instead.
<b>Use of external frequency converter</b>	For most three-phase CHI, CHIU pumps a frequency converter can be used. Single-phase motors are not suitable for frequency converter operation. In many cases where an external frequency converter is used it is necessary to protect the motor against voltage peaks higher than 650 V (peak value). In these cases it is often less expensive to ask for phase insulation in the pump than use a filter such as an LC filter. Grundfos offers pumps with phase insulation to protect the pump against voltage peaks up to 1000 V (peak values). This is a customized version, and the supplier of the frequency converter must be consulted.
<b>Harting plug</b>	Harting plugs are available for easier replacement of pumps.
<b>Terminal box position</b>	Other terminal box positions are possible.

### Shaft seals

BUBV, BUBE, BQQE, BQQV are standard for CHI, CHIU pumps.

Shaft seals with FFKM or FXM O-ring material are recommended for applications where the pumped liquid may damage the standard O-ring material.

### Connections and other variants

<b>Pipe connections</b>	NPT and Rp threads are available.
<b>TriClamp connection</b>	TriClamp connections are of a hygienic design with a sanitary coupling for use in the pharmaceutical and food industry.
<b>Electropolished pump sleeve</b>	To substantially reduce the risk of corrosion. For use in the pharmaceutical and food industry.

### Certificates and nameplates

<b>Certificates</b>	Certificate of compliance with the order Test certificate Inspection certificate Standard test report
<b>Extra nameplate</b>	
<b>UR-marked motor</b>	If the UL-listed product according to UL778 is not available, a pump with UR-marked motor according to UL1004 can be offered as an alternative.

### Special tests or cleaning

Silicone-free
Grease-free
Rinse in alcohol

### Pumps

<b>Low-temperature pump</b>	Exposed to temperatures below -20 °C, coolant pumps may require neck rings with a different diameter or without neck ring in order to prevent impeller drag. If neck rings are removed a drop in head performance must be expected. In some extreme cases, -30 °C cold liquids can be pumped by a CHI. Contact Grundfos.
-----------------------------	--

### Product options

<b>Extra low noise level CHI 15 and 20</b>	Under the right conditions, it is possible to remove the ventilator fan and thus reduce the noise level.
<b>Pump colour</b>	All colours are possible.

### Pumping of refrigerants

The CHIU is able to pump liquid gases, such as R134a.

pumpwarehouse.com.au  
Ph 1300 661 417

<b>V7031261</b> 1207	<b>GB</b>
Repl. V7031261 0807	

Subject to alterations.