

# CHI

## Installation and operating instructions

GB D F I E P GR NL S FIN DK  
PL RU H SI HR SER RO BG CZ SK TR  
EE LT LV UA



## **(GB)** Declaration of Conformity

We **Grundfos** declare under our sole responsibility that the products **CHI 2, CHI 4, CHI 8, CHI 12, CHI 15 and CHI 20**, to which this declaration relates, are in conformity with the Council Directives on the approximation of the laws of the EC Member States relating to

- Machinery (98/37/EC).
- Electrical equipment designed for use within certain voltage limits (2006/95/EC).  
Standards used: EN 60335-1: 2002 and EN 60335-2-51: 2003.
- Electromagnetic compatibility (2004/108/EC).

## **(F)** Déclaration de Conformité

Nous **Grundfos** déclarons sous notre seule responsabilité que les produits **CHI 2, CHI 4, CHI 8, CHI 12, CHI 15 et CHI 20** auxquels se réfère cette déclaration sont conformes aux Directives du Conseil concernant le rapprochement des législations des Etats membres CE relatives à

- Machines (98/37/CE).
- Matériel électrique destiné à employer dans certaines limites de tension (2006/95/CE).  
Standards utilisés: EN 60335-1: 2002 et EN 60335-2-51: 2003.
- Compatibilité électromagnétique (2004/108/CE).

## **(E)** Declaración de Conformidad

Nosotros **Grundfos** declaramos bajo nuestra única responsabilidad que los productos **CHI 2, CHI 4, CHI 8, CHI 12, CHI 15 y CHI 20** a los cuales se refiere esta declaración son conformes con las Directivas del Consejo relativas a la aproximación de las legislaciones de los Estados Miembros de la CE sobre

- Máquinas (98/37/CE).
- Material eléctrico destinado a utilizarse con determinadas límites de tensión (2006/95/CE).  
Normas aplicadas: EN 60335-1: 2002 y EN 60335-2-51: 2003.
- Compatibilidad electromagnética (2004/108/CE).

## **(GR)** Δήλωση Συμμόρφωσης

Εμείς η **Grundfos** δηλώνουμε με αποκλειστικά δική μας ευθύνη ότι τα προϊόντα **CHI 2, CHI 4, CHI 8, CHI 12, CHI 15 και CHI 20**

συμμορφώνονται με την Οδηγία του Συμβουλίου επί της σύγκλισης των νόμων των Κρατών Μελών της Ευρωπαϊκής Ένωσης σε σχέση με τα

- Μηχανήματα (98/37/ΕΚ).
- Ηλεκτρικές συσκευές σχεδιασμένες για χρήση εντός ορισμένων ορίων ηλεκτρικής τάσης (2006/95/ΕΚ).  
Πρότυπα που χρησιμοποιήθηκαν: EN 60335-1: 2002 και EN 60335-2-51: 2003.
- Ηλεκτρομαγνητική συμβατότητα (2004/108/ΕΚ).

## **(S)** Försäkran om överensstämmelse

Vi **Grundfos** försäkrar under ansvar, att produkterna **CHI 2, CHI 4, CHI 8, CHI 12, CHI 15 och CHI 20**, som omfattas av denna försäkran, är i överensstämmelse med Rådets Direktiv om inbördes närmande till EU-medlemsstaternas lagstiftning, avseende

- Maskinell utrustning (98/37/EC).
- Elektrisk utrustning avsedd för användning inom vissa spänningsgränser (2006/95/EC).  
Använda standarder: EN 60335-1: 2002 och EN 60335-2-51: 2003.
- Elektromagnetisk kompatibilitet (2004/108/EC).

## **(DK)** Overensstemmelseserklæring

Vi **Grundfos** erklærer under ansvar, at produkterne **CHI 2, CHI 4, CHI 8, CHI 12, CHI 15 og CHI 20**, som denne erklæring omhandler, er i overensstemmelse med Rådets direktiver om indbyrdes tilnærmelse til EF medlemsstaternes lovgivning om

- Maskiner (98/37/EF).
- Elektrisk materiel bestemt til anvendelse inden for visse spændingsgrænser (2006/95/EF).  
Anvendte standarder: EN 60335-1: 2002 og EN 60335-2-51: 2003.
- Elektromagnetisk kompatibilitet (2004/108/EF).

## **(D)** Konformitätserklärung

Wir **Grundfos** erklären in alleiniger Verantwortung, dass die Produkte **CHI 2, CHI 4, CHI 8, CHI 12, CHI 15 und CHI 20**, auf die sich diese Erklärung bezieht, mit den folgenden Richtlinien des Rates zur Angleichung der Rechtsvorschriften der EG-Mitgliedstaaten übereinstimmen

- Maschinen (98/37/EG).
- Elektrische Betriebsmittel zur Verwendung innerhalb bestimmter Spannungsgrenzen (2006/95/EG).  
Normen, die verwendet wurden: EN 60335-1: 2002 und EN 60335-2-51: 2003.
- Elektromagnetische Verträglichkeit (2004/108/EG).

## **(I)** Dichiarazione di Conformità

Noi **Grundfos** dichiariamo sotto la nostra esclusiva responsabilità che i prodotti **CHI 2, CHI 4, CHI 8, CHI 12, CHI 15 e CHI 20** ai quali questa dichiarazione se riferisce sono conformi alle Direttive del Consiglio concernente il ravvicinamento delle legislazioni degli Stati membri CE relative a

- Macchine (98/37/CE).
- Materiale elettrico destinato ad essere utilizzato entro certi limiti di tensione (2006/95/CE).  
Standard usati: EN 60335-1: 2002 e EN 60335-2-51: 2003.
- Compatibilità elettromagnetica (2004/108/CE).

## **(P)** Declaração de Conformidade

Nós **Grundfos** declaramos sob nossa única responsabilidade que os produtos **CHI 2, CHI 4, CHI 8, CHI 12, CHI 15 e CHI 20** aos quais se refere esta declaração estão em conformidade com as Directivas do Conselho das Comunidades Europeias relativas à aproximação das legislações dos Estados Membros respeitantes à

- Máquinas (98/37/CE).
- Material eléctrico destinado a ser utilizado dentro de certos limites de tensão (2006/95/CE).  
Normas utilizadas: EN 60335-1: 2002 e EN 60335-2-51: 2003.
- Compatibilidade electromagnética (2004/108/CE).

## **(NL)** Overeenkomstigheidsverklaring

Wij **Grundfos** verklaren geheel onder eigen verantwoordelijkheid dat de producten **CHI 2, CHI 4, CHI 8, CHI 12, CHI 15 en CHI 20** waarop deze verklaring betrekking heeft in overeenstemming zijn met de Richtlijnen van de Raad inzake de onderlinge aanpassing van de wetgevingen van de

- Lid-Staten betreffende
- Machines (98/37/EG).
- Elektrisch materiaal bestemd voor gebruik binnen bepaalde spanningsgrenzen (2006/95/EG).  
Normen: EN 60335-1: 2002 en EN 60335-2-51: 2003.
- Elektromagnetische compatibiliteit (2004/108/EG).

## **(FIN)** Vastaavuusvakuutus

Me **Grundfos** vakuutamme yksin vastuullisesti, että tuotteet **CHI 2, CHI 4, CHI 8, CHI 12, CHI 15 ja CHI 20**, jota tämä vakuutus koskee, noudattavat direktiivejä jotka käsittelevät EY:n jäsenvaltioiden koneellisia laitteita koskevien lakien yhdenmukaista seur:

- Koneet (98/37/EY).
- Määrättyjen jänniterajoitusten puitteissa käytettävät sähköiset laitteet (2006/95/EY).  
Käytetyt standardit: EN 60335-1: 2002 ja EN 60335-2-51: 2003.
- Elektromagneettinen vastaa vuus (2004/108/EY).

## **(PL)** Deklaracja zgodności

My, **Grundfos**, oświadczamy z pełną odpowiedzialnością, że nasze wyroby **CHI 2, CHI 4, CHI 8, CHI 12, CHI 15 oraz CHI 20**, których deklaracja niniejsza dotyczy, są zgodne z następującymi wytycznymi Rady d/s jednolitego przepisów prawnych krajów członkowskich EG:

- maszyny (98/37/EG).
- wyposażenie elektryczne do stosowania w określonym zakresie napięć (2006/95/EG).  
zastosowane normy: EN 60335-1: 2002 i EN 60335-2-51: 2003.
- zgodność elektromagnetyczna (2004/108/EG).

## **(RU)** Декларация о соответствии

Мы, фирма **Grundfos**, со всей ответственностью заявляем, что изделия **CHI 2, CHI 4, CHI 8, CHI 12, CHI 15 и CHI 20**, к которым и относится данное свидетельство, отвечают требованиям следующих указаний Совета ЕС об унификации законодательных предписаний стран-членов ЕС:

- Машиностроение (98/37/EC).
- Электрические машины для эксплуатации в пределах определенного диапазона значений напряжения (2006/95/EC).  
Применявшиеся стандарты: Евростандарт EN 60335-1: 2002 и EN 60335-2-51: 2003.
- Электромагнитная совместимость (2004/108/EC).

## **(SI)** Izjava o ustreznosti

Ми, **Grundfos**, pod polno odgovornostjo izjavljamo, da so izdelki **CHI 2, CHI 4, CHI 8, CHI 12, CHI 15 in CHI 20**, na katere se ta izjava nanaša, v skladu z naslednjimi smernicami Sveta za uskladitev pravnih predpisov držav članic Evropske skupnosti:

- Stroji (98/37/EG).
- Električna pogonska sredstva za uporabo v določenih napetostnih mejah (2006/95/EG).  
Uporabljeni normi: EN 60335-1: 2002 in EN 60335-2-51: 2003.
- Elektromagnetna kompatibilnost (2004/108/EG).

## **(SER)** Izjava o konformitetu

Ми, **Grundfos**, izjavljamo pod potpunom odgovornošću da su proizvodi **CHI 4, CHI 8, CHI 12, CHI 15 i CHI 20**, na koje se ova izjava odnosi, u skladu sa sledećim smernicama i uputstvima Saveta za usaglašavanje pravnih propisa članica Evropske unije:

- mašine (98/37/EG).
- električna oprema razvijena za korišćenje unutar određenih naponskih granica (2006/95/EG),  
korišćeni standardi: EN 60335-1: 2002 i EN 60335-2-51: 2003.
- elektromagnetna usaglašenost (2004/108/EG).

## **(BG)** Декларация за съответствие

Ние, фирма **Grundfos** заявяваме с пълна отговорност, че продуктите **CHI 4, CHI 8, CHI 12, CHI 15 и CHI 20**, за които се отнася настоящата декларация, отговарят на следните указания на Съвета за уеднаквяване на правните разпоредби на държавите членки на ЕС:

- Машини (98/37/EO).
- Електрически машини и съоръжения за употреба в рамките на определените граници на напрежение на електрическия ток (2006/95/EO).  
Приложени норми: EN 60335-1: 2002 и EN 60335-2-51: 2003.
- Електромагнитна поносимост (2004/108/EO).

## **(SK)** Prehlásenie o konformite

My firma **Grundfos**, na svoju plnú zodpovednosť prehlasujeme, že výrobky **CHI 4, CHI 8, CHI 12, CHI 15, CHI 20**, na ktoré sa toto prehlásenie vzťahuje, sú v súlade s nasledovnými smernicami Rady pre zblíženie právnych predpisov členských zemí Európskej únie:

- Stroje (98/37/EG).
- Elektrické prevádzkové prostriedky, použité v určitom napätovom rozsahu (2006/95/EG).  
Použitá norma: EN 60335-1: 2002 a EN 60335-2-51: 2003.
- Elektromagnetická kompatibilita (2004/108/EG).

## **(EE)** Vastavuse deklaratsioon

Meie, **Grundfos**, deklareerime enda ainuvastutusel, et toode **CHI 8, CHI 12, CHI 15 ja CHI 20**, mille kohta käesolev juhend käib, on vastavuses EL nõukogu Direktiividega EMÜ liikmesriikide seaduste ühitamise kohta, mis käsitlevad:

- Masinad (98/37/EC).
- Madalapinge-elektriseadmed (2006/95/EC).  
Kasutatud standardid: EN 60335-1: 2002 ja EN 60335-2-51: 2003.
- Elektromagnetilist ühilduvust (2004/108/EC).

## **(H)** Konformitási nyilatkozat

Ми, а **Grundfos**, egyedüli felelősséggel kijelentjük, hogy az **CHI 2, CHI 4, CHI 8, CHI 12, CHI 15 és CHI 20** termékek, amelyekre jelen nyilatkozat vonatkozik, megfelelnek az Európai Unió tagállamainak jogi irányelveit összehangoló tanács alábbi irányelveinek:

- Gépek (98/37/EK).
- Meghatározott feszültség határokron belül használt elektromos eszközök (2006/95/EK).  
Alkalmazott szabványok: EN 60335-1: 2002 és EN 60335-2-51: 2003.
- Elektromágneses összeférhetőség (2004/108/EK).

## **(HR)** Izjava o usklađenosti

Ми, **Grundfos**, izjavljujemo uz punu odgovornost, da su proizvodi **CHI 2, CHI 4, CHI 8, CHI 12, CHI 15 i CHI 20**, na koje se ova izjava odnosi, sukladni smjernicama Savjeta za prilagodbu propisa država članica EZ:

- Strojevi (98/37/EZ).
- Električni pogonski uređaji za korištenje unutar određenih granica napona (2006/95/EZ).  
Korištene norme: EN 60335-1: 2002 i EN 60335-2-51: 2003.
- Elektromagnetska kompatibilnost (2004/108/EZ).

## **(RO)** Declarație de conformitate

Noi, **Grundfos**, declarăm asumându-ne întreaga responsabilitate că produsele **CHI 4, CHI 8, CHI 12, CHI 15, CHI 20** la care se referă această declarație sunt în conformitate cu Directivele Consiliului în ceea ce privește alinierea legislațiilor Statelor Membre ale CE, referitoare la:

- Utilaje (98/37/CE).
- Echipamente electrice destinate utilizării între limite exacte de tensiune (2006/95/CE).  
Standarde aplicate: EN 60335-1: 2002 și EN 60335-2-51: 2003.
- Compatibilitate electromagnetică (2004/108/CE).

## **(CZ)** Prohlášení o shodě

My firma **Grundfos** prohlašujeme na svou plnou odpovědnost, že výrobky **CHI 4, CHI 8, CHI 12, CHI 15 a CHI 20** na něž se toto prohlášení vztahuje, jsou v souladu s ustanoveními směrnice Rady pro sblížení právních předpisů členských států Evropského společenství v oblastech:

- strojírenství (98/37/EG).
- provozování spotřebičů v toleranci napětí (2006/95/EG),  
použitá norma: EN 60335-1: 2002 a EN 60335-2-51: 2003.
- elektromagnetická kompatibilita (2004/108/EG).

## **(TR)** Uygunluk Bildirgesi

Biz **Grundfos** olarak, bu beyanda belirtilen **CHI 4, CHI 8, CHI 12, CHI 15** ve **CHI 20** ürünlerinin,

- Makina (98/37/EC).
- Belli voltaj sınırlarında kullanılmak üzere üretilmiş elektrik donanımları (2006/95/EC).
- Kullanılan standartlar: EN 60335-1: 2002 ve EN 60335-2-51: 2003.
- Elektromanyetik uyumluluk (2004/108/EC).

ile ilgili olarak Avrupa topluluğu'na Üye Devletlerin yasalarında yer alan Belediye Yönetmeliklerine uygun olduğunu, tüm sorumluluğu bize ait olmak üzere beyan ederiz.

## **(LT)** Atitikties deklaracija

Mes, **Grundfos**, su visa atsakomybe pareiškiame, kad gaminiai **CHI 4, CHI 8, CHI 12, CHI 15 ir CHI 20**, kuriems skirta ši deklaracija, atitinka Tarybos Direktyvas dėl Europos Ekonominės Bendrijos šalių narių įstatymų suderinimo šiose srityse:

- Mašinai (98/37/EC).
- Elektriniai prietaisai, skirti naudoti tam tikrose įtampų ribose (2006/95/EC).
- Naudojami standartai: EN 60335-1: 2002 ir EN 60335-2-51: 2003.
- Elektromagnetinė sąveikojamba (2004/108/EK).

## LV Paziņojums par atbilstību prasībām

Sabiedrība Grundfos ar pilnu atbildību dara zināmu, ka izstrādājumi CHI 8, CHI 12, CHI 15 un CHI 20, uz kuriem attiecas šis paziņojums, atbilst šādām Padomes direktīvām par tuvināšanas EK dalībvalstu likumdošanas normām:

- Mašīnbūve (98/37/EK).
- Elektriskais aprīkojums, kas paredzēts lietošanai zināmu sprieguma robežvērtību ietvaros (2006/95/EK).  
Piemērotie standarti: EN 60335-1: 2002 un EN 60335-2-51: 2003.
- Elektromagnētiskā savienojamība (2004/108/EK).

## UA Свідчення про відповідність вимогам

Ми, фірма Grundfos, із усією відповідальністю заявляємо, що вироби CHI 8, CHI 12, CHI 15 і CHI 20 до яких і відноситься дане свідцтво відповідають вимогам наступних указівок Ради ЄСЄ про уніфікацію законодавчих розпоряджень країн-членів ЄСЄ:

- Машинобудування (98/37/ЄС).
- Електричні машини для експлуатації в межах визначеного діапазону значень напруги (2006/95/ЄС).  
Стандарти, що застосовувалися:  
Євростандарт EN 60335-1: 2002 і EN 60335-2-51: 2003.
- Електромагнітна сумісність (2004/108/ЄС).

Bjerringbro, 01/June/2006

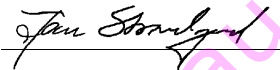

Jan Strandgaard  
Technical Director

# CHI

Installation and operating instructions	6	GB
Montage- und Betriebsanleitung	11	D
Notice d'installation et d'entretien	18	F
Istruzioni di installazione e funzionamento	24	I
Instrucciones de instalación y funcionamiento	30	E
Instruções de instalação e funcionamento	36	P
Οδηγίες εγκατάστασης και λειτουργίας	42	GR
Installatie- en bedieningsinstructies	48	NL
Monterings- och driftsinstruktion	53	S
Asennus- ja käyttöohjeet	58	FIN
Monterings- og driftsinstruktion	63	DK
Instrukcja montażu i eksploatacji	68	PL
Руководство по монтажу и эксплуатации	75	RU
Szerelési és üzemeltetési utasítás	83	H
Navodila za montažo in obratovanje	90	SI
Montažne i pogonske upute	97	HR
Uputstvo za montažu i upotrebu	103	SER
Instrucțiuni de instalare și utilizare	110	RO
Упътване за монтаж и експлоатация	115	BG
Montážní a provozní návod	122	CZ
Návod na montáž a prevádzku	129	SK
Montaj ve kullanım kılavuzu	136	TR
Paigaldus- ja kasutusjuhend	143	EE
Įrengimo ir naudojimo instrukcija	148	LT
Uzstādīšanas un ekspluatācijas instrukcija	153	LV
Інструкції з монтажу та експлуатації	158	UA

# CONTENTS

GB

	Page
<b>1. Applications</b>	<b>6</b>
<b>2. Technical data</b>	<b>6</b>
2.1 Temperatures	6
2.2 Maximum permissible operating pressure	6
2.3 Maximum inlet pressure	7
2.4 Minimum inlet pressure	7
2.5 Sound pressure level	7
<b>3. Installation</b>	<b>7</b>
<b>4. Electrical connection</b>	<b>8</b>
4.1 Frequency converter operation	9
<b>5. Start-up</b>	<b>9</b>
5.1 Priming	9
5.2 Checking of direction of rotation	9
<b>6. Operation and maintenance</b>	<b>9</b>
6.1 Frequency of starts and stops	9
6.2 Maintenance	9
6.3 Frost protection	9
6.4 Cleaning	9
6.5 Service	9
<b>7. Fault finding chart</b>	<b>10</b>
<b>8. Disposal</b>	<b>10</b>



Prior to installation, read these installation and operating instructions. Installation and operation must comply with local regulations and accepted codes of good practice.

## 1. Applications

Grundfos pumps, type CHI, are horizontal multistage centrifugal pumps of the non self-priming type designed for pumping thin non-explosive liquids.

The CHI pump with integral motor is fitted to a base plate.

The pump is made of corrosion-resistant materials, which makes it ideally suited for water supply and a wide range of applications in industry, agriculture and in the food industry.



The pump must not be used for the transfer of inflammable liquids such as diesel oil, petrol or similar liquids.

**Note:** The pump has been tested with water only.

The pump is designed for pumping clean water, domestic hot water, aqueous solutions, cleaning solutions, suspensions or light oils and other liquids with a density and viscosity corresponding to those of water. The liquids must not contain abrasive particles or fibres.

When pumping liquids with a density or viscosity higher than that of water, motors with correspondingly higher outputs must be used.

As standard, the mechanical shaft seal for the CHI pump is available in six versions with different material combinations, see the stamping code on the pump nameplate.

Example: Type CHI 4-50 A-W-G-BQQE.

Code	Shaft seal materials	
	Seal faces	Rubber parts
<b>BQQE</b> <b>BQQV</b>	SiC/SiC*	EPDM FKM
<b>BUBE</b> <b>BUBV</b>	Tungsten carbide/ carbon	EPDM FKM
**BAQE **BAQV	Carbon graphite/ SiC*	EPDM FKM

\* SiC: Silicon carbide.

\*\* Only CHI 15 and CHI 20.

## 2. Technical data

### 2.1 Temperatures

Pump types	O-ring material/liq-uid	Liquid	Temperature [°C]
	EPDM		-20 +120
CHI 2	FKM/liquid containing water		-20 +90
CHI 4			
CHI 8	FKM/oil without water		-20 +120
CHI 12			
	FKM/oil without water (where cUL and CSA approval is required)		-20 +110
CHI 15			-20
CHI 20			+70
Ambient temperature	All	At a relative humidity of maximum 95%	-20 +40
Storage temperature	All		-50 +70

### 2.2 Maximum permissible operating pressure

10 bar.

### 2.3 Maximum inlet pressure

The actual inlet pressure + pressure when the pump is operating against a closed valve must always be lower than the "maximum permissible operating pressure".

### 2.4 Minimum inlet pressure

The minimum inlet pressure "H" in metres head required during operation to avoid cavitation in the pump can be calculated from the following formula:

$$H = p_b \times 10.2 - \text{NPSH} - H_f - H_v - H_s$$

$p_b$  = Barometric pressure in bar.  
(Barometric pressure can be taken as 1 bar.)

In closed systems,  $p_b$  indicates the system pressure in bar.

**NPSH** = Net Positive Suction Head  
(to be read from the NPSH curves on pages 164 to 166 at the highest flow the pump will be delivering).

$H_f$  = Friction loss in suction pipe in metres head.

$H_v$  = Vapour pressure, see fig. G, page 167.  
 $t_m$  = liquid temperature.

$H_s$  = Safety margin = 0.5 metres head.

If the calculated value of H is positive, the pump can operate with a maximum suction lift of "H" metres.

If the calculated value of H is negative, a minimum suction head of "H" metres is required during operation of the pump to prevent cavitation.

#### Example:

$p_b = 1$  bar.

Pump type: CHI 12, 50 Hz.

Flow rate: 12 m<sup>3</sup>/h.

NPSH (from fig. D, page 165): 3.0 metres.

$H_f = 3.0$  metres head.

Liquid temperature: 90°C.

$H_v$  (from fig. G, page 167): 7.2 metres head.

$H = p_b \times 10.2 - \text{NPSH} - H_f - H_v - H_s$  [metres head].

$H = 1 \times 10.2 - 3.0 - 3.0 - 7.2 - 0.5 = -3.5$  metres head.

This means that a suction head of 3.5 metres is required during operation.

Pressure calculated in bar:  $3.5 \times 0.0981 = 0.35$  bar.

Pressure calculated in kPa:  $3.5 \times 9.81 = 34.4$  kPa.

### 2.5 Sound pressure level

The sound pressure level of the pump is lower than 70 dB(A).

## 3. Installation

Install the pump as shown in fig. 1, and so that adequate air supply reaches the motor cooling fan.

A solid foundation should be provided for the pump, which can be secured by bolts, if required.

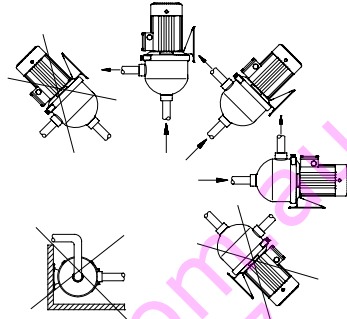

Fig. 1 Installation positions

The pump sleeve can be turned 45° from the 12 o'clock position. See fig. 2.

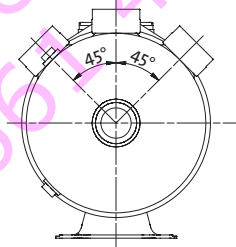

Fig. 2 Position of discharge port

**Note:** If the position of the pump sleeve is to be changed, contact Grundfos. During this procedure, the gaskets may be damaged and the pump will leak.

The pump should be installed in such a position that no air can accumulate in the pump sleeve. If this is not possible, a vent screw for direct mounting in the pump sleeve can be ordered from Grundfos, see fig. 7.

## Pipe connections:

Suction and discharge ports (fig. 3):

Pump type	Suction/discharge port	Torque [Nm]
CHI 2:	Rp 1	50 - 60
CHI 4:	Rp 1½	50 - 60
CHI 8:	Rp 1½	50 - 60
CHI 12:	Rp 1½	50 - 60
CHI 15:	Rp 2	50 - 60
CHI 20:	Rp 2	50 - 60

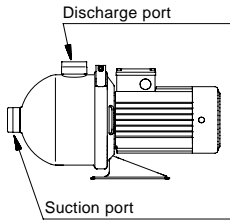

Fig. 3 Suction and discharge ports

Install the pipes so that air locks are avoided, especially on the suction side of the pump. Shown in fig. 4.

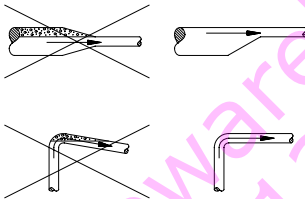

Fig. 4 Pipe installation

Isolating valves should be fitted on either side of the pump to avoid draining the system if the pump needs to be cleaned or repaired.

If pumps are installed close to living accommodation, it is advisable to fit anti-vibration mountings either side of the pump and between foundation and pump to prevent vibration being transmitted through the pipework. This applies especially to pumps installed in concrete buildings.

Install the pump so that it is not stressed or strained by the pipework, especially tension caused by variations in temperature.

If the pumps are installed in long pipes, these should be adequately supported before and after the pump.

If there is any danger of the pump running against a closed valve in the discharge pipe, a bypass should be installed on the discharge side of the pump to ensure that adequate cooling and lubrication water is circulated through the pump (a minimum flow equal to 10% of the nominal flow is needed at all times).

## 4. Electrical connection

The electrical connection and protection should be carried out in accordance with local regulations. The connections are shown in the wiring diagram inside the terminal box cover.



Never make any connections in the pump terminal box unless the electricity supply has been switched off.

The pump must be connected to an external mains switch.

The operating voltage and frequency are marked on the nameplate. Please make sure that the motor is suitable for the electricity supply on which it will be used.

**Single-phase motors** incorporate a thermal overload switch and require no additional motor protection.

**Note:** Single-phase motors with UL approval (1 x 115/230 V, 60 Hz) do not have built-in motor protection and therefore require external motor protection.

**Three-phase motors** must be connected to an approved motor starter.

On pumps with the *base plate fitted to the pump part*, the terminal box can be turned to three positions, in 90° steps, see fig. 5.

To change the position of the terminal box, proceed as follows:

1. Remove the four screws securing the motor to the motor stool.
2. Turn the motor to the required position.
3. Replace and tighten the four screws.

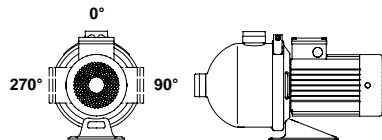

Fig. 5 Base plate fitted to pump

Pumps with the *base plate fitted to the motor* must be installed with the terminal box in position 0°, see fig. 6.

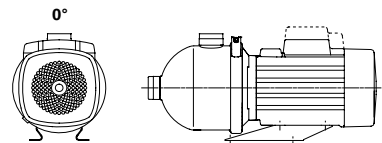

Fig. 6 Base plate fitted to motor

## 4.1 Frequency converter operation

All three-phase motors can be connected to a frequency converter.

Depending on the frequency converter type, this may cause increased acoustic noise from the motor. Furthermore, it may cause the motor to be exposed to detrimental voltage peaks.

**Note:** The motors must be protected against voltage peaks higher than 650 V (peak value) between the supply terminals.

The above disturbances, i.e. both increased acoustic noise and detrimental voltage peaks, can be eliminated by fitting an LC filter between the frequency converter and the motor.

For further information, please contact the frequency converter supplier or Grundfos.

## 5. Start-up



At high system temperatures, the pump may be burning hot. Do not touch it.

### 5.1 Priming

Before start-up, or if the pump has been drained, the pump must be filled with liquid and vented.

Proceed as follows:

**In closed systems** or open systems where the liquid level is above the pump inlet:

1. Close the discharge isolating valve.
2. Remove the priming plug in the pump sleeve, see fig. 7.
3. Slowly open the isolating valve in the suction pipe until a steady stream of liquid runs out of the priming port.



The escaping liquid may be scalding hot. Therefore, care must be taken to ensure that the liquid does not cause personal injury or damage to other components.

4. Replace the priming plug and tighten securely.
5. Completely open the isolating valve(s).

Priming plug G 3/8 /  
vent screw (accessory)

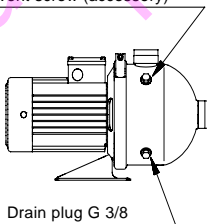

Drain plug G 3/8

Fig. 7 Plugs in pump sleeve

**In open systems** where the liquid level is below the pump inlet, the suction pipe must also be filled with liquid and vented before the pump is started:

1. Close the discharge isolating valve.
2. Remove the priming plug in the pump sleeve.
3. Pour liquid through the priming hole until the suction pipe and the pump are completely filled with liquid.
  - If the suction pipe does not slope downwards away from the pump, air must be purged from the suction pipe while the pump is being filled.
  - Filling may take place at the highest point of the suction pipe if this is above the priming plug of the pump.
4. Replace the priming plug and tighten securely.

### 5.2 Checking of direction of rotation

Arrows on the fan cover indicate the correct direction of rotation. The pump should rotate counter-clockwise when seen from the motor fan.

## 6. Operation and maintenance

### 6.1 Frequency of starts and stops

Maximum 100 starts per hour.

### 6.2 Maintenance

Pump and motor are maintenance-free.

### 6.3 Frost protection

Pumps which are not being used during periods of frost should be drained to avoid damage.

Remove the priming and drain plugs and allow the pump to drain. Do not replace the plugs until the pump is to be used again.



The escaping liquid may be scalding hot. Therefore, care must be taken to ensure that the liquid does not cause personal injury or damage to other components.

### 6.4 Cleaning

If the pump has been used for pumping aggressive or polluted liquids, it should be flushed through with clean water to avoid corrosion or sediment in case the pump is not being used for some time.

### 6.5 Service



If a pump has been used for a liquid which is injurious to health or toxic, the pump will be classified as contaminated.

If Grundfos is requested to service the pump, Grundfos must be contacted with details about the pumped liquid, etc. *before* the pump is returned for service. Otherwise Grundfos can refuse to accept the pump for service.

Possible costs of returning the pump are paid by the customer.

## 7. Fault finding chart



Before removing the terminal box cover, make sure that the electricity supply has been switched off. The pumped liquid may be scalding hot and under high pressure. Before any removal or dismantling of the pump, the system must therefore be drained or the isolating valves on either side of the pump must be closed.

GB

Fault	Cause
1. Motor does not start when the motor starter is operated.	a) Supply failure. b) Fuses blown. c) Motor starter overload has tripped out. d) Main contacts in starter are not making contact or the coil is faulty. e) Control circuit fuses are defective.
2. Starter overload trips out immediately when supply is switched on.	a) One fuse is blown. b) Contacts in overload are faulty. c) Cable connection is loose or faulty. d) Motor winding is defective. e) Pump stiff and not free to run. f) Overload setting too low.
3. Motor starter overload trips out occasionally.	a) Overload setting too low. b) Periodic supply failure. c) Low voltage at peak times.
4. Pump does not run when starter is operated.	a) Check 1 a), b), d) and e).
5. Pump capacity not constant.	a) Pump inlet pressure is too low. b) Suction pipe partly blocked by impurities. c) Pump takes in air.
6. Pump runs but gives no water.	a) Suction pipe blocked by impurities. b) Foot or non-return valve blocked in closed position. c) Leakage in suction pipe. d) Air in suction pipe or pump.
7. Pump runs backwards when switched off.	a) Leakage in suction pipe. b) Foot or non-return valve defective. c) Foot valve blocked in open or partly open position.

## 8. Disposal

This product or parts of it must be disposed of in an environmentally sound way:

1. Use the public or private waste collection service.
2. If this is not possible, contact the nearest Grundfos company or service workshop.

pumpwarehouse.com.au  
Ph 1300 661 417

<b>004E0011</b> 0607	<b>185</b>
Repl. 4E0011 0806	