

MARINE PRODUCT DATA SHEET

OEM: 3901-2204 (Blaster)
AFTERMARKET: 3901-2214 (Blaster)

APPLICATION

Marine fresh or salt water wash down installations. Other uses may include 12V DC pressurized water systems in cabins. This pump may be used for general water transfer.

PUMP:

Type: 3 Chamber Diaphragm
 Ports: 1/2"-14 NPSM-Male.
 Liquid: 130 °F [54 °C] Max
 Dry-Prime: 6 feet [1.82 M]
 Inlet PSI: 30 PSI [2.1 Bar] Max
 Run Dry: Yes

ELECTRICAL:

Motor: 12VDC Permanent Magnet, Intermittent Duty
 Protection: Thermal Overload, Automatic Restart
 Leads: 16 AWG, 16" [40 cm] Red +, 13" [33 cm] Black -
 Fuse: 10 Amp Recommended
 Control: Adjustable Switch. Shut-Off 45 PSI [3.1 Bar] ± 5 PSI [0.4Bar] Restart 25 PSI [1.7 Bar] ± 5 PSI [0.4 Bar]

MATERIALS:

Housing: Polypro
 Valves: EPDM
 Diaphragm: Santoprene
 Hardware: Stainless Steel

APPROVALS:

Ignition Protection 8846, CE

WARRANTY:

1 Year Limited Warranty.
 Contact SHURflo for details

SHIPPING:

Net Weight: 4.8 Lbs [2.2 Kg] each
 Carton Quantity: 12
 Carton Weight: 58 Lb [26.3 Kg]
 Carton Size: 27"L x 18"W x 11"H
 [60.9cm x 45.7cm x 27.9cm]

RELATED DOCUMENTS:

Catalog: MS-030-140
 Installation Manual: 911-732
 Applications Spec Guide: MS-020-005



Perfect for tough washdown applications, such as fish box, scaling, and anchor chain cleaning, these rugged self-priming pumps deliver high lift, can run dry without damage, and won't overheat with extended use. Pump is ignition protected and switch is sealed against water damage.

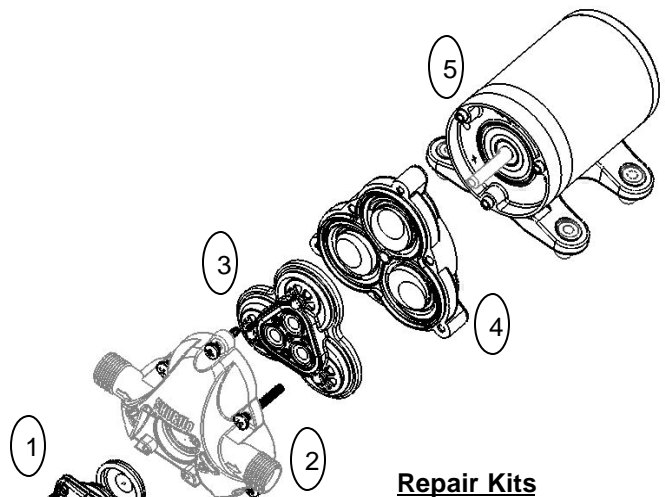

Repair Kits

Number	Description	Part Number
1	Switch Assy	94-706-00
2	Upper Hsg	94-706-01
3	Valve Assy	94-706-02
4	Drive Assy	94-706-06
5	Motor	94-77-043-17

TYPICAL PERFORMANCE

PRESSURE		FLOW		CURRENT
BAR	PSI	GPM	LPM	AMPS
0.0	0	3.80	14.3	4.15
0.7	10	2.54	9.61	4.94
1.4	20	1.83	6.92	5.24
2.1	30	1.34	5.07	5.57
2.8	40	0.95	3.59	5.74

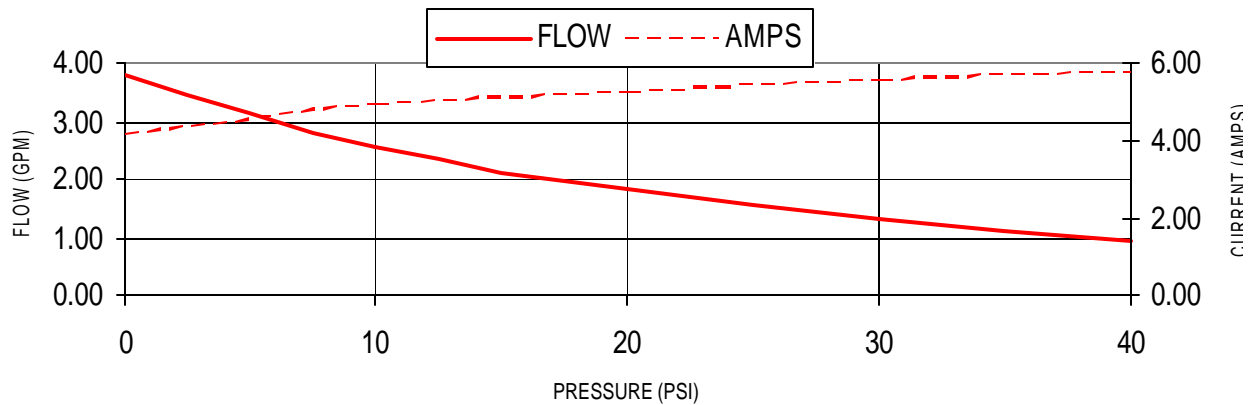

DIMENSIONS [mm]

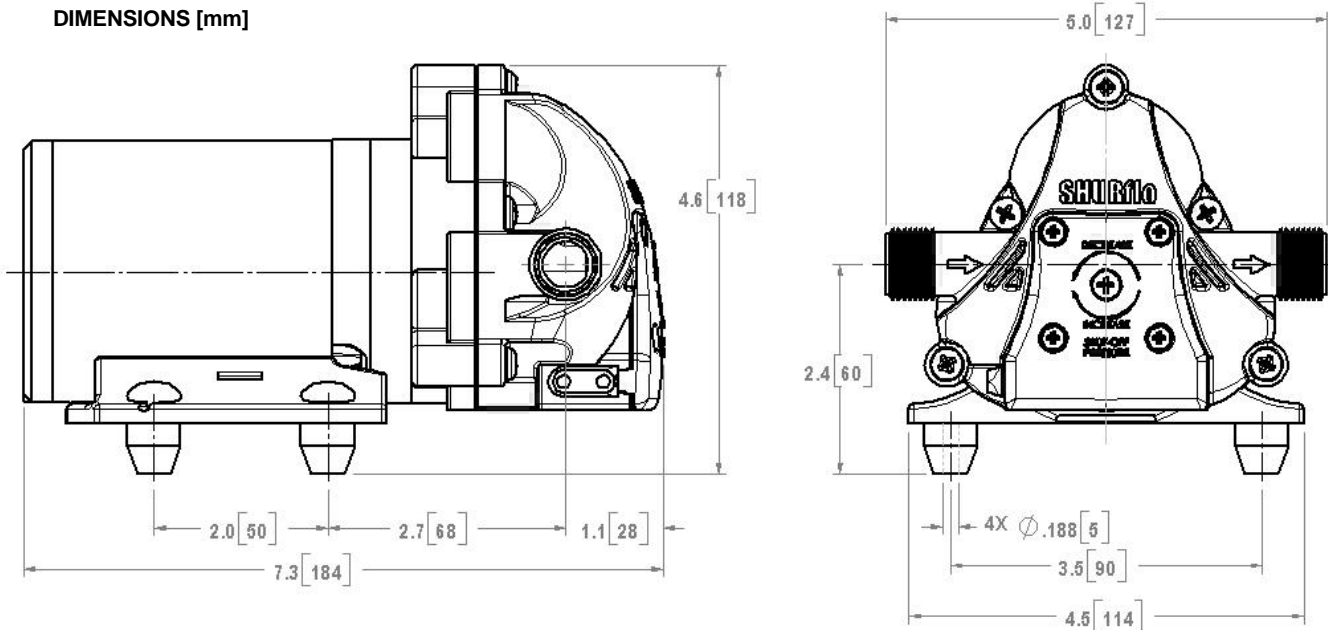

Visit our Web Site at <http://www.shurflo.com>
 Shurflo reserves the right to update specifications,
 change prices, or make substitutions without notice.

SHURflo
 5900 Katella Avenue
 Cypress, CA 90630
 Phone (562) 795-5200
 Toll Free (800) 854-3218
 Fax (562) 795-7564

SHURflo East
 52748 Park Six Court
 Elkhart, IN 46514-5427
 Phone (562) 795-5200
 Toll Free (800) 854-3218
 Fax (574) 264-2169

SHURflo Europe, Middle East, Africa
Pentair Water Belgium bvba
 Industriepark Wolfstee, Toekomstlann 30
 B-2200 Herentals, Belgium
 Phone +32-14-283500
 Fax +32-14-283505



Pentair Water

FLOW TECHNOLOGIES GROUP

5900 Katella Ave, Cypress, CA 90630
 Phone (800) 854-3218 • (562) 795-5200 • Fax (562) 795-7564
www.shurflo.com