

Unilift AP35B



TM01 4187 4998

Fig. 29 Unilift AP35B

Unilift AP35B is a single-stage submersible pump designed for pumping effluent.

The pump is suitable for:

- groundwater lowering
- pumping in drainage pits
- pumping in surface water pits with inflow from roof gutters, shafts, tunnels, etc.
- emptying of ponds, tanks, etc.
- pumping of fibre-containing effluent from laundries and industries
- pumping of domestic effluent from septic tanks and sludge treating systems
- pumping of domestic effluent without discharge from water closets.

Liquid temperature range: 0°C to +40°C.

Automatic operation

The pump is available for automatic as well as manual operation and can be installed in a permanent installation or used as a portable pump. The pump is available:

- with level switch fitted for automatic on/off operation between two liquid levels (single-phase pumps)
- without level switch for manual on/off operation.

Pumps fitted with level switches can also be used for manual on/off operation. In this case, the level switch must be secured in an upward-pointing position.

Pump housing

Pump housing with an outstanding design for submersible wastewater pumps, resulting in a high head.

The pump housing is made of a steel tube with a smooth surface and a hydraulically correct shape ensuring free passage of particles.

Base, pump inlet and pump housing are fastened to the motor by means of four springs enabling quick and easy dismantling.

Discharge port

All Unilift AP35B pumps have a threaded horizontal discharge port of R 2".

Shaft and bearings

The stainless steel shaft rotates in maintenance-free prelubricated ball bearings.

Impeller

The stainless steel impeller is a vortex impeller with L-shaped blades and a clearance of 35 mm in the pump housing. The blades are curved backwards to reduce any harmful effect from solid particles and to minimise power consumption. The impeller has a protective cap to prevent the deposit of long-fibred material.

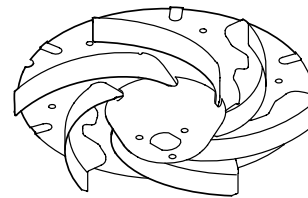

TM00 5478 0895

Fig. 30 Impeller

Shaft seal

The shaft seal is a combination of a mechanical, bellows shaft seal and a lip seal with 80 ml oil between. Seal faces are made of silicon carbide.

Motor cable

The motor is a single- or three-phase asynchronous dry-running motor.

Enclosure class: IP 68
Insulation class: F (155°C)
Cable type: H07RN-F.

Single-phase motors have built-in thermal protection.

Materials

Component	Material	DIN W.-Nr.	AISI
Pump housing	Stainless steel	1.4301	304
Impeller	Stainless steel	1.4301	304
Washer	Stainless steel	1.4301	304
Protective cap	Novolen 2360 Kx		
Motor unit complete	Parts in contact with liquid: Stainless steel	1.4401	316
Shaft with rotor	Stainless steel/silumin	1.4305	
Motor cable	Neoprene		
O-rings	NBR rubber		
Spring	Stainless steel	1.4310	
Pump inlet	Stainless steel	1.4301	304
Base	Polycarbonate		
Oil	Shell Ondina 15, non-toxic		

Selection

The below overview is suitable for the selection of the correct size of Unilift AP35B pumps used in stationary applications.

To ensure that the discharge pipe is self-cleaning, the calculation of the pipe lengths is based on:

- the use of steel pipes
- a minimum flow velocity through the vertical discharge pipe (2") of 1 m/s
- a minimum flow velocity through the horizontal discharge pipe (2½") of 0.7 m/s.

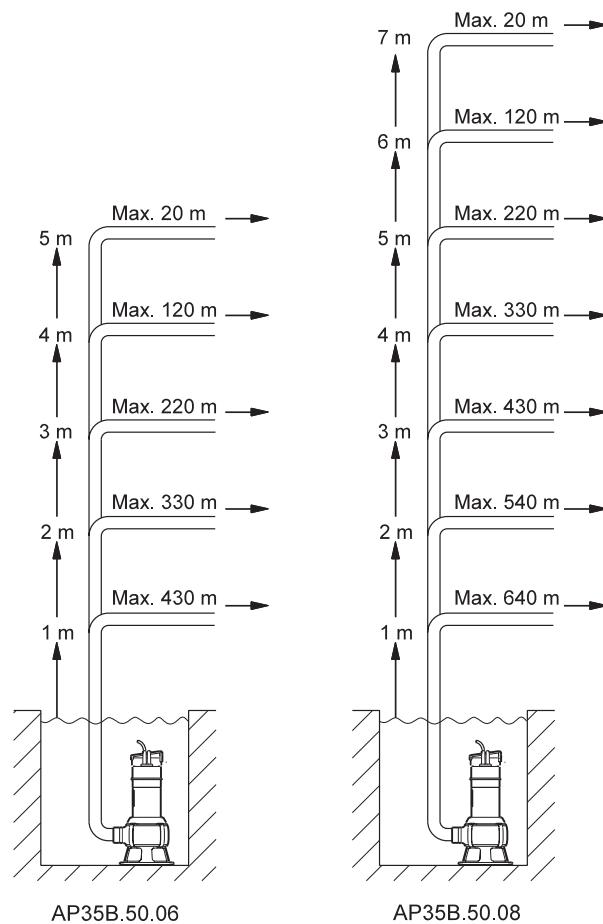

TMO3 1881 3305

Fig. 31 Overview of maximum lengths of combined vertical and horizontal discharge pipes

The above overview is only intended as a guide. Grundfos is not liable for any faulty installations based on the overview.

The vertical height of the discharge pipe should be measured from the pump stop level.

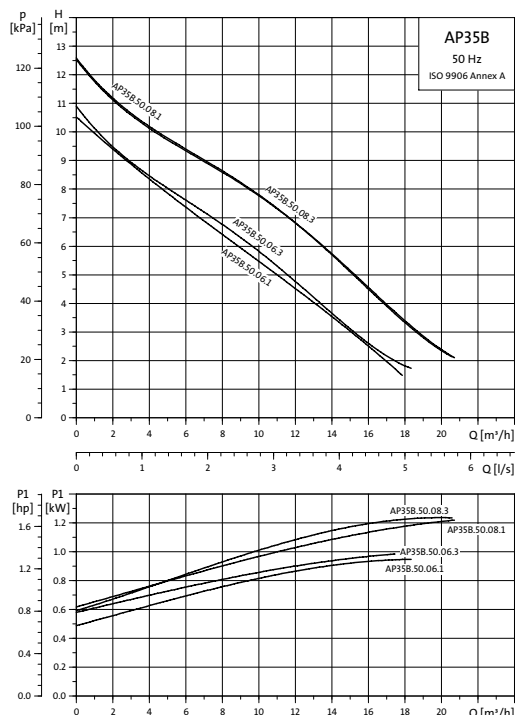

Fig. 32 Performance curves

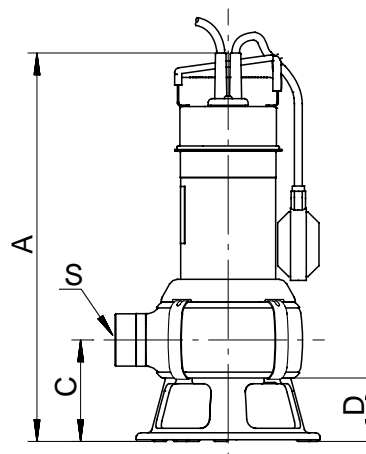

Fig. 33 Dimensions

TM01 9219 1500

Pump type	Voltage [V]	P ₁ [kW]	P ₂ [kW]	I _n [A]	Cos φ	C [μF]	I _{start} / I _n	Dimensions [mm]				Weight [kg]	Cable length and plug
								A	C	D	S		
AP35B.50.06.A1.V	1 x 230	0.99	0.6	4.4	0.98	3.1	13.8	443	116	73	R 2	8.5	5 m with Schuko plug
AP35B.50.06.1.V	1 x 230	0.99	0.6	4.4	0.98	3.1	13.8	443	116	73	R 2	8.5	10 m with Schuko plug
AP35B.50.06.3.V	3 x 400	0.95	0.6	1.55	0.89	5.2	8.0	443	116	73	R 2	7.4	5 m without plug
AP35B.50.08.A1.V	1 x 230	1.22	0.8	5.44	0.98	3.4	18.4	468	116	73	R 2	10.0	5 m with Schuko plug
AP35B.50.08.1.V	1 x 230	1.22	0.8	5.44	0.98	3.4	18.4	468	116	73	R 2	10.0	10 m with Schuko plug
AP35B.50.08.3.V	3 x 400	1.23	0.8	1.98	0.89	5.4	10.6	468	116	73	R 2	8.4	5 m without plug

Start/stop level

Pump type	Start [mm]	Stop [mm]
AP35B	633	270

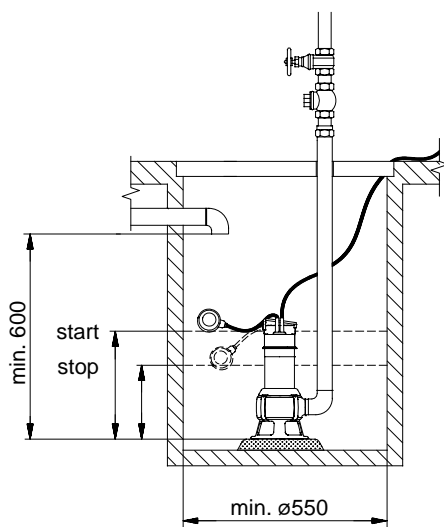
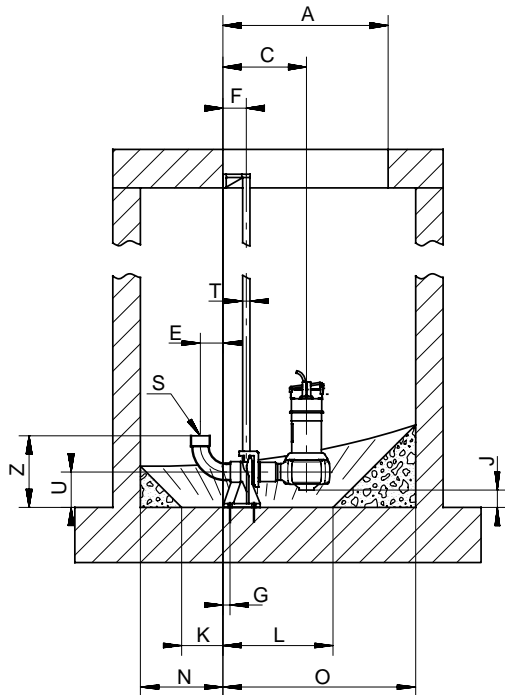

Fig. 34 Minimum installation dimensions

TM03 1914 3305

Unilift AP35B installations



TM01 3593 0299

Fig. 35 Unilift AP35B installation, one pump

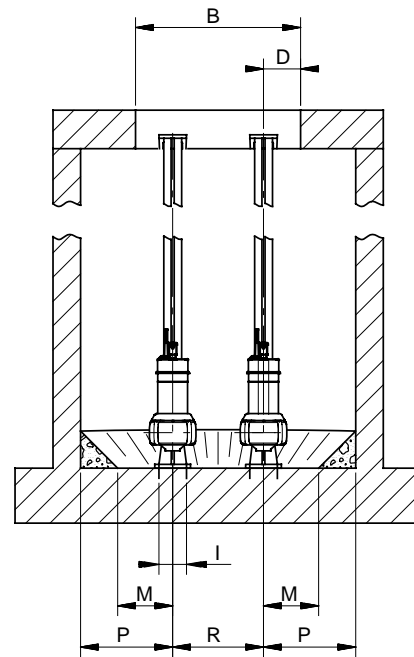

TM01 3592 0299

Fig. 36 Unilift AP35B installation, two pumps

One-pump installation on auto-coupling

Pump type	Dimensions [mm]																			
	A	B	C	D	E	F	G	I	J	K	L	M	N	O	P	R	S	T	U	Z
AP35B.50.06	ø600	ø600	304	135	82	85	65	100	76	150	400	200	300	700	500	-	R 2	¾"	130	261
AP35B.50.08	ø600	ø600	304	135	82	85	65	100	76	150	400	200	300	700	500	-	R 2	¾"	130	261

Two-pump installation on auto-coupling

Pump type	Dimensions [mm]																			
	A	B	C	D	E	F	G	I	J	K	L	M	N	O	P	R	S	T	U	Z
AP35B.50.06	600	600	304	135	82	85	26	100	76	150	400	200	300	700	335	330	R 2	¾"	130	261
AP35B.50.08	600	600	304	135	82	85	26	100	76	150	400	200	300	700	35	330	R 2	¾"	130	261