

MARINE PRODUCT DATA SHEET

OEM: 4901-6202 (Pro-Bait Master)
AFTERMARKET: 4901-6212 (Pro-Bait Master)

APPLICATION

Marine bait and livewell installations.
Other uses may include 12V DC fresh or salt water wash down and pressurized water systems in cabins.
This pump may be used for general water transfer.

PUMP:

Type: 4 Chamber Diaphragm
Ports: 1/2"-14 NPSM-Male.
Liquid: 130 °F [54 °C] Max
Dry-Prime: 6 feet [1.82 M]
Inlet PSI: 30 PSI [2.1 Bar] Max
Run Dry: Yes

ELECTRICAL:

Motor: 12VDC Permanent Magnet, Continuous Duty
Protection: Thermal Overload, Automatic Restart
Leads: 14 AWG, 16" [40 cm] Red +, 13" [33 cm] Black -
Fuse: 15 Amp Recommended
Control: Adjustable Switch. Shut-Off at 45 PSI [3.1 Bar] ± 5 PSI [0.4 Bar]. Restart at 25 PSI [1.8 Bar] ± 5 PSI [0.4Bar]

MATERIALS:

Housing: Nylon
Valves: EPDM
Diaphragm: Santoprene
Hardware: Stainless Steel

APPROVALS:

Ignition Protection 8846, CE

WARRANTY:

2 Year Limited Warranty.
Contact SHURflo for details

SHIPPING:

Net Weight (boxed): 6.5 Lbs [2.94 Kg] each
Carton Quantity: 6
Carton Weight: 45 Lb [20.4 Kg]
Approx. Carton Size: 24"L x 18"W x 6"H
[60.9cm x 45.7cm x 15.2cm]

RELATED DOCUMENTS:

Catalog: MS-030-140
Installation Manual: 911-738
Applications Spec Guide: MS-020-005



The Pro Baitmaster is excellent for livewell or washdown application in harsh marine environments. The SHURCote seamless motor shell and sealed switch protects the pump from splashed liquids.

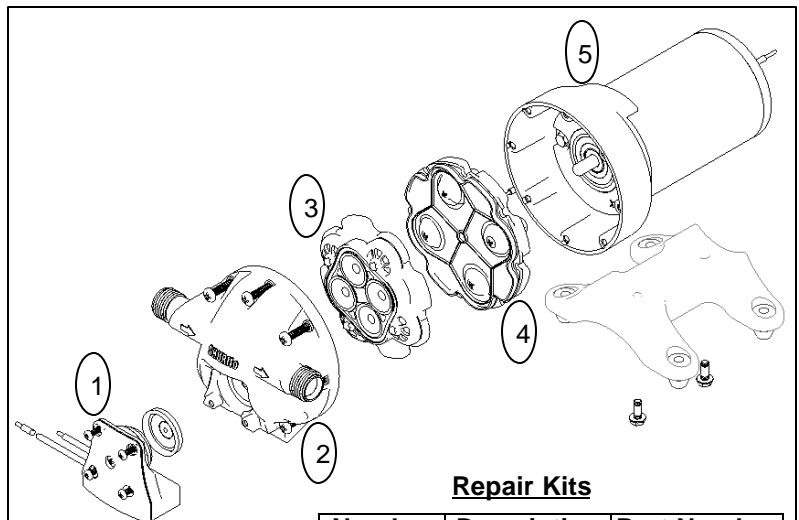

Repair Kits

Number	Description	Part Number
1	Switch Assy	94-668-00
2	Upper Hsg	94-670-01
3	Valve Assy	94-669-00
4	Drive Assy	94-670-00
5	Motor	94-77-025-17

TYPICAL PERFORMANCE

PRESSURE		FLOW		CURRENT
BAR	PSI	GPM	LPM	AMPS
0.0	0	4.0	15.1	4.6
0.7	10	3.5	12.5	5.3
1.4	20	3.2	10.1	6.4
2.1	30	2.95	10.2	7.5
2.8	40	2.75	9.0	8.4

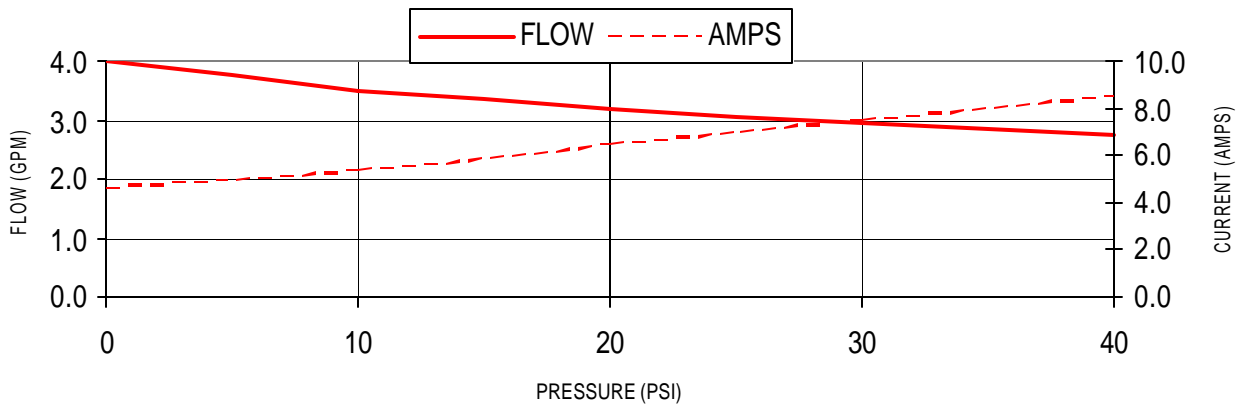

DIMENSIONS [mm]

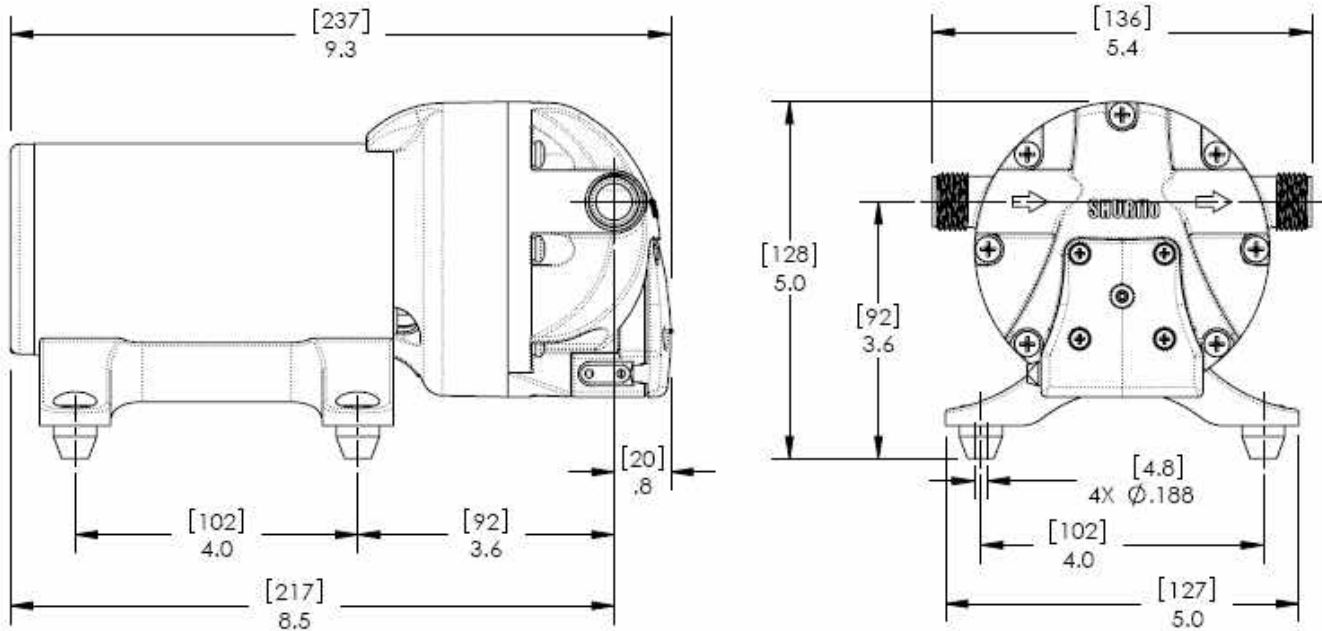

Visit our Web Site at <http://www.shurflo.com>
 Shurflo reserves the right to update specifications,
 change prices, or make substitutions without notice.

SHURflo
 5900 Katella Avenue
 Cypress, CA 90630
 Phone (562) 795-5200
 Toll Free (800) 854-3218
 Fax (562) 795-7564

SHURflo East
 52748 Park Six Court
 Elkhart, IN 46514-5427
 Phone (562) 795-5200
 Toll Free (800) 854-3218
 Fax (574) 264-2169

SHURflo Europe, Middle East, Africa
Pentair Water Belgium bvba
 Industriepark Wolfstee, Toekomstlann 30
 B-2200 Herentals, Belgium
 Phone +32-14-283500
 Fax +32-14-283505



Pentair Water

FLOW TECHNOLOGIES GROUP
 5900 Katella Ave, Cypress, CA 90630
 Phone (800) 854-3218 • (562) 795-5200 • Fax (562) 795-7564
www.shurflo.com